

# NAIS

## LOW-PROFILE SURFACE-MOUNT RELAY

# TQ-SMD RELAYS

### FEATURES

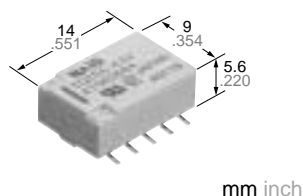

- **Low-profile:** 6 mm .236 inch in height conforming to EIA standards (Tape height: max. 6.5 mm .256 inch )
- **Tape and reel package** is available as standard packing style
- **Surge withstand between contacts and coil:** 2,500 V
- **Breakdown voltage between contacts and coil:** 1,500 V
- **High capacity:** 2 A
- **High sensitivity:**  
2 Form C; 140 mW power consumption (Single side stable type)

### SPECIFICATIONS

Contact			
Arrangement	2 Form C		
Initial contact resistance, max. (By voltage drop 6 V DC 1 A)	75 mOhm		
Contact material	Gold-clad silver alloy		
Rating	Nominal switching capacity (resistive load)	2 A 30 V DC, 0.5 A 125 V AC	
	Max. switching power (resistive load)	60 W, 62.5 VA	
	Max. switching voltage	220 V DC, 125 V AC	
	Max. switching current	2 A	
	Min. switching capacity *1	10 µA 10 mV DC	
Nominal operating power	Single side stable	140 mW (1.5 to 12 V DC) 200 mW (24 V DC) 300 mW (48 V DC)	
	1 coil latching	70 mW (1.5 to 12 V DC) 100 mW (24 V DC)	
	2 coil latching	140 mW (1.5 to 12 V DC) 200 mW (24 V DC)	
Expected life (min. operations)	Mechanical (at 180 cpm)	10 <sup>8</sup>	
	Electrical (at 20 cpm)	2 A 30 V DC resistive	10 <sup>5</sup>
		1 A 30 V DC resistive	2 x 10 <sup>5</sup>
		0.5 A 125 V AC resistive	10 <sup>5</sup>

Characteristics		
Initial insulation resistance*1	Between open contacts	Min. 1,000 MOhm (at 500 V DC)
	Between contact sets	1,000 Vrms for 1 min. (Detection current: 10 mA)
	Between contact and coil	1,500 Vrms for 1 min. (Detection current: 10 mA)
Initial surge voltage	Between open contacts (10¥160 ms)	1,500 V (FCC Part 68)
	Between contacts and coil (2¥10 ms)	2,500 V (Bellcore)
Temperature rise*2 (at 20°C)	Max. 50°C	
Operate time [Set time]*3 (at 20°C)	Max. 4 ms (Approx. 2 ms) [Max. 4 ms (Approx. 2 ms)]	
Release time [Reset time]*4 (at 20°C)	Max. 4 ms (Approx. 1 ms) [Max. 4 ms (Approx. 2 ms)]	
Shock resistance	Functional*5	Min. 750 m/s <sup>2</sup> {75 G}
	Destructive*6	Min. 1,000 m/s <sup>2</sup> {100 G}
Vibration resistance	Functional*7	200 m/s <sup>2</sup> {20G}, 10 to 55 Hz at double amplitude of 3.3 mm
	Destructive	294 m/s <sup>2</sup> {30G}, 10 to 55 Hz at double amplitude of 5 mm
Conditions for operation, transport and storage*8 (Not freezing and condensing at low temperature)	Ambient temperature	-40°C to +85°C*3 -40°F to +185°F
	Humidity	5 to 85% R.H.
Unit weight	Approx. 2 g .071 oz	

**Note:**  
\*1 This value can change due to the switching frequency, environmental conditions, and desired reliability level, therefore it is recommended to check this with the actual load.

**Remarks**  
 \* Specifications will vary with foreign standards certification ratings.  
 \*1 Measurement at same location as "Initial breakdown voltage" section.  
 \*2 By resistive method, nominal voltage applied to the coil; contact carrying current: 2 A.  
 \*3 Nominal voltage applied to the coil, excluding contact bounce time.  
 \*4 Nominal voltage applied to the coil, excluding contact bounce time without diode.  
 \*5 Half-wave pulse of sine wave: 6 ms; detection time: 10 µs  
 \*6 Half-wave pulse of sine wave: 6 ms  
 \*7 Detection time: 10 µs  
 \*8 Refer to 4. Conditions for operation, transport and storage mentioned in Cautions for use (Page 178).

## ORDERING INFORMATION

Ex. TQ 2 SA - L - 3V - Z

Contact arrangement	Surface-mount availability	Operating function	Coil voltage (DC)	Packing style
2: 2 Form C	SA: Standard surface-mount terminal type SL: High connection reliability surface-mount terminal type SS: Space saving surface-mount terminal type	Nil: Single side stable L: 1 coil latching L2: 2 coil latching	1.5, 3, 4.5, 5, 6, 9, 12, 24, 48* V	Nil: Tube packing Z: Tape and reel packing (picked from the 6/7/8/9/10-pin side)

\*48 V coil type: Single side stable only

Notes: 1. Tape and reel (picked from 1/2/3/4/5-pin side) is also available by request. Part No. suffix "-X" is needed when ordering. (ex.) TQ2SA-3V-X  
2. Tape and reel packing symbol "-Z" or "-X" are not marked on the relay.

## Surface-mount terminal variation

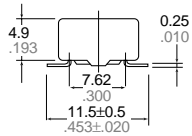
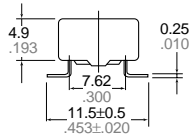
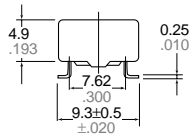
Variation	Terminal style	Ambient environment	
		Normal environments (indoor)	Drastic temperature fluctuations (outdoor)
SA type (Standard surface-mount terminal type)		Recommended	—
SL type (Highly connection reliability surface-mount terminal type)		Recommended	Recommended
SS type (Space saving surface-mount terminal type)		Recommended	Recommended

## TYPES

## 1. Single side stable

Part No.	Nominal voltage, V DC	Pick-up voltage, V DC (max.)	Drop-out voltage, V DC (min.)	Nominal operating current, mA ( $\pm 10\%$ )	Coil resistance, Ohm ( $\pm 10\%$ )	Nominal operating power, mW	Max. allowable voltage, V DC
TQ2SO-1.5 V	1.5	1.13	0.15	93.8	16	140	2.2
TQ2SO-3 V	3	2.25	0.3	46.7	64.3	140	4.5
TQ2SO-4.5 V	4.5	3.38	0.45	31	145	140	6.7
TQ2SO-5 V	5	3.75	0.5	28.1	178	140	7.5
TQ2SO-6 V	6	4.5	0.6	23.3	257	140	9
TQ2SO-9 V	9	6.75	0.9	15.5	579	140	13.5
TQ2SO-12 V	12	9	1.2	11.7	1,028	140	18
TQ2SO-24 V	24	18	2.4	8.3	2,880	200	36
TQ2SO-48 V	48	36	4.8	6.3	7,680	300	57.6

## 2. 1 coil latching

Part No.	Nominal voltage, V DC	Set voltage, V DC (max.)	Reset voltage, V DC (max.)	Nominal operating current, mA ( $\pm 10\%$ )	Coil resistance, Ohm ( $\pm 10\%$ )	Nominal operating power, mW	Max. allowable voltage, V DC
TQ2SO-L-1.5 V	1.5	1.13	1.13	46.9	32	70	2.2
TQ2SO-L-3 V	3	2.25	2.25	23.3	128.6	70	4.5
TQ2SO-L-4.5 V	4.5	3.38	3.38	15.6	289.3	70	6.7
TQ2SO-L-5 V	5	3.75	3.75	14	357	70	7.5
TQ2SO-L-6 V	6	4.5	4.5	11.7	514	70	9
TQ2SO-L-9 V	9	6.75	6.75	7.8	1,157	70	13.5
TQ2SO-L-12 V	12	9	9	5.8	2,057	70	18
TQ2SO-L-24 V	24	18	18	4.2	5,760	100	36

# TQ-SMD

## 3. 2 coil latching

Part No.	Nominal voltage, V DC	Set voltage, V DC (max.)	Reset voltage, V DC (max.)	Nominal operating current, mA ( $\pm 10\%$ )	Coil resistance, Ohm ( $\pm 10\%$ )	Nominal operating power, mW	Max. allowable voltage, V DC
TQ2S○-L2-1.5 V	1.5	1.13	1.13	93.8	16	140	2.2
TQ2S○-L2-3 V	3	2.25	2.25	46.7	64.3	140	4.5
TQ2S○-L2-4.5 V	4.5	3.38	3.38	31	145	140	6.7
TQ2S○-L2-5 V	5	3.75	3.75	28.1	178	140	7.5
TQ2S○-L2-6 V	6	4.5	4.5	23.3	257	140	9
TQ2S○-L2-9 V	9	6.75	6.75	15.5	579	140	13.5
TQ2S○-L2-12 V	12	9	9	11.7	1,028	140	18
TQ2S○-L2-24 V	24	18	18	8.3	2,880	200	36

○: For each surface-mounted terminal variation, input the following letter.

SA type: A, SL type: L, SS type: S

Notes: 1. Specified value of the pick-up, drop-out, set and reset voltage is with the condition of square wave coil pulse.

2. Standard packing: Tube: 50 pcs.; Case; 1,000 pcs.; Tape and reel: 500 pcs./reel

3. In case of 5 V transistor drive circuit, it is recommended to use 4.5 V type relay.

## DIMENSIONS

mm inch

### SA type

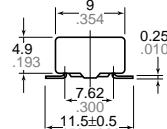
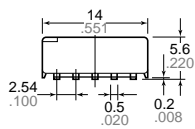

### Recommendable mounting pad (Top view) SA type

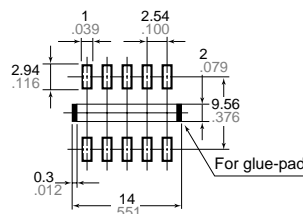

### SL type

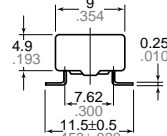
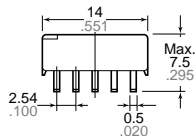

### SL type

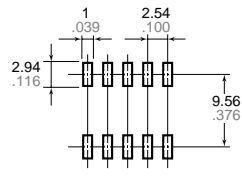

### SS type

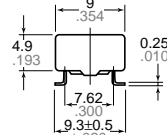
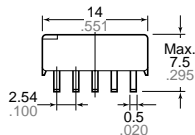

### SS type

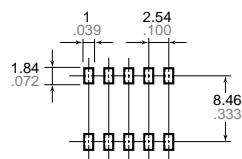

General tolerance:  $\pm 0.3 \pm 0.012$

Tolerance:  $\pm 0.1 \pm 0.004$

### Schematic (Top view)

•Single side stable (Deenergized condition)

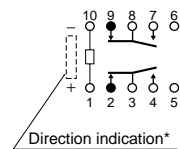

\*Orientation stripe located on top of relay.

•1-coil latching (Reset condition)

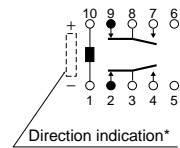

\*Orientation stripe located on top of relay.

•2-coil latching (Reset condition)

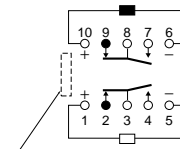

\*Orientation stripe located on top of relay.

## REFERENCE DATA

### 1. Maximum switching capacity

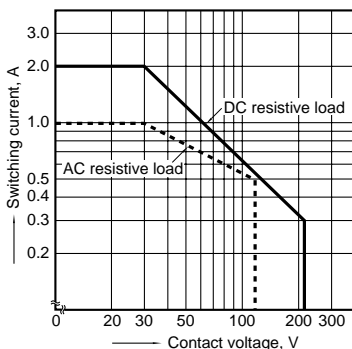

### 2. Life curve

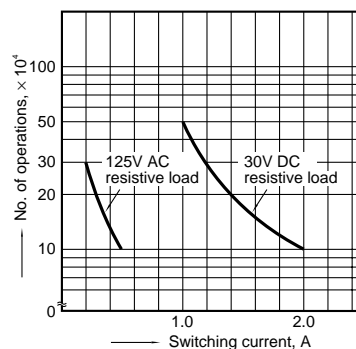

### 3. Mechanical life (mounting by IRS method)

Tested sample: TQ2SA-12V, 10 pcs.

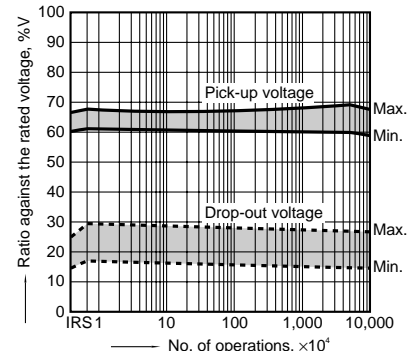

## 4.-(1) Electrical life (2 A 30 V DC resistive load)

Tested sample: TQ2SA-12V, 6 pcs.  
 Operating frequency: 20 cpm  
 Change of pick-up and drop-out voltage  
 (mounting by IRS method)

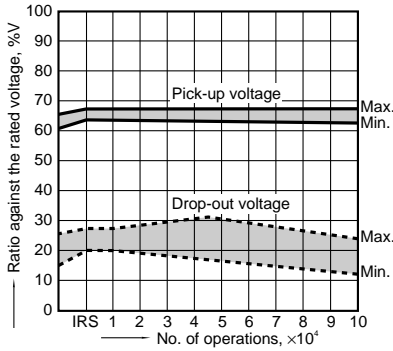

Change of contact resistance  
 (mounting by IRS method)

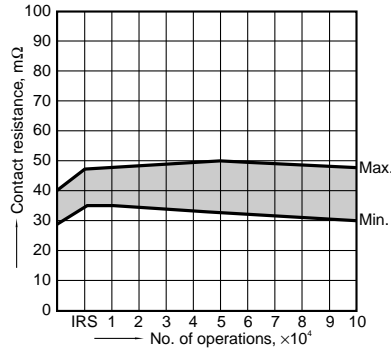

## 4.-(2) Electrical life (0.5 A 125 V AC resistive load)

Tested sample: TQ2SA-12V, 6 pcs.  
 Operating frequency: 20 cpm  
 Change of pick-up and drop-out voltage  
 (mounting by IRS method)

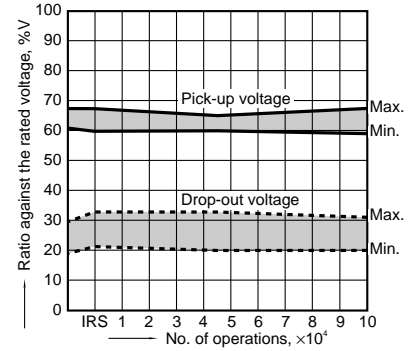

Change of contact resistance  
 (mounting by IRS method)

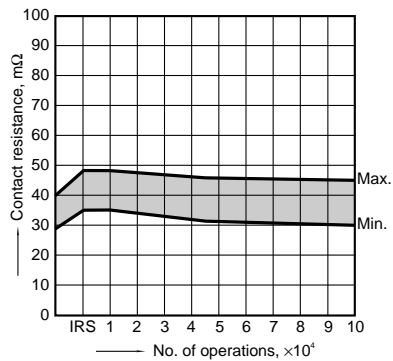

## 5. Coil temperature rise

Tested sample: TQ2SA-12V, 6 pcs.  
 Point measured: Inside the coil  
 Ambient temperature: 25°C 77°F

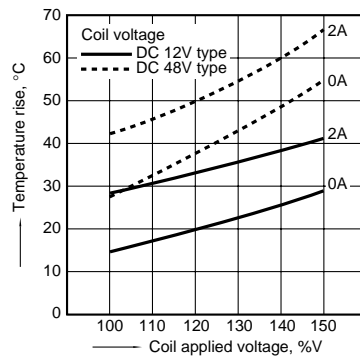

## 6. Operate/release time

Tested sample: TQ2SA-12V, 6 pcs.

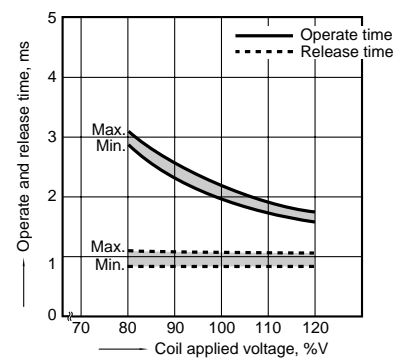

## 7. Distribution of pick-up and drop out voltage

Tested sample: TQ2SA-12V, 50 pcs.

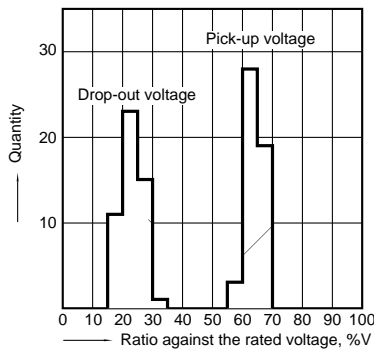

## 8. Distribution of set and reset voltage

Tested sample: TQ2SA-L-12V, 30 pcs.

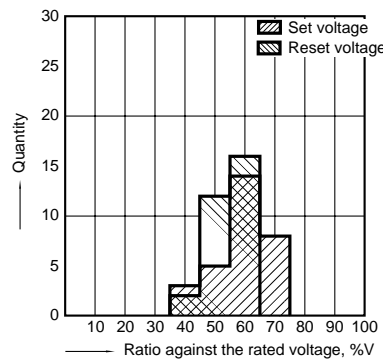

## 9. Ambient temperature characteristics

Tested sample: TQ2SA-12V, 5 pcs.

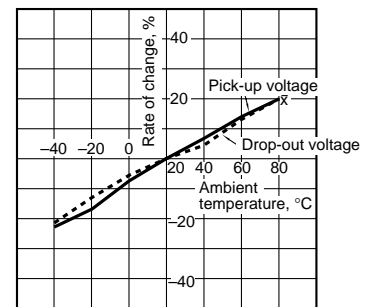

## 10. Distribution of contact resistance

Tested sample: TQ2SA-5V, 30 pcs. (30 x 4 contacts)

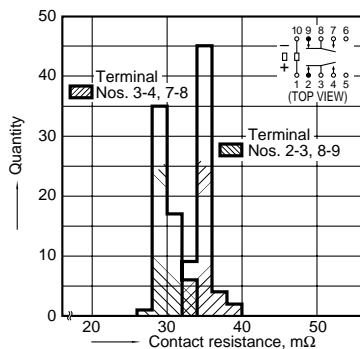

## 11.-(1) High-frequency characteristics

Isolation characteristics

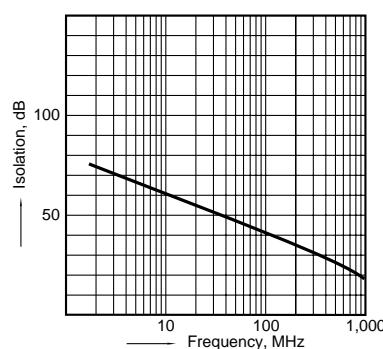

## 11.-(2) High-frequency characteristics

Insertion loss characteristics

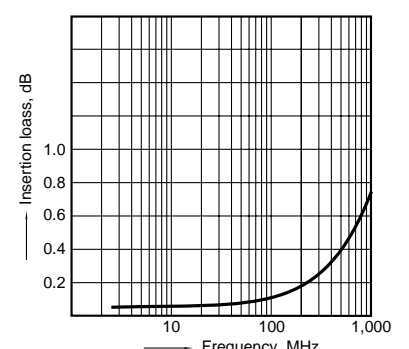

# TQ-SMD

12.-(1) Malfunctional shock (single side stable)  
 Tested sample: TQ2SA-12V, 6 pcs

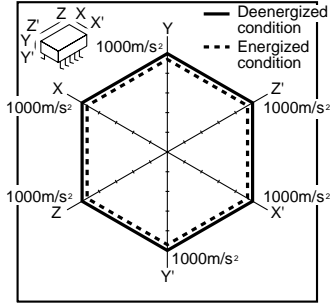

12.-(2) Malfunctional shock (latching)  
 Tested sample: TQ2SA-L2-12V, 6 pcs.

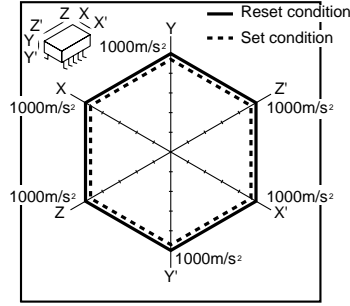

13.-(1) Influence of adjacent mounting  
 Tested sample: TQ2SA-12V, 5 pcs.

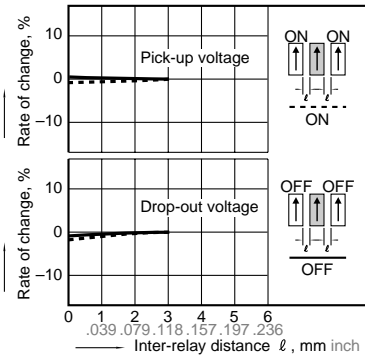

13.-(2) Influence of adjacent mounting  
 Tested sample: TQ2SA-12V, 6 pcs.

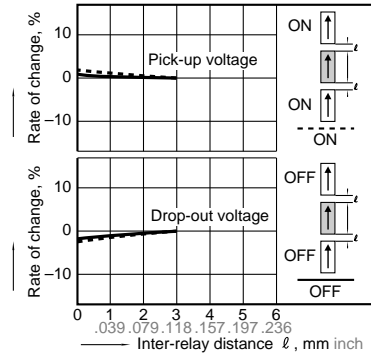

13.-(3) Influence of adjacent mounting  
 Tested sample: TQ2SA-12V, 6 pcs.

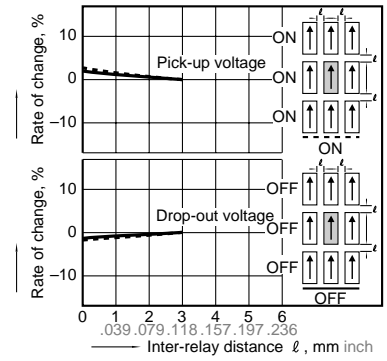

## 14. Pulse dialing test

Tested sample: TQ2SA-12V, 6 pcs.  
 (35 mA 48 V DC wire spring relay load)  
 Circuit

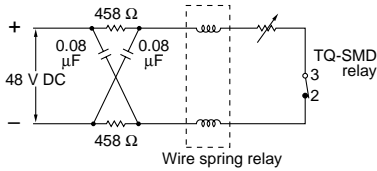

Change of pick-up and drop-out voltage  
 (mounting by IRS method)

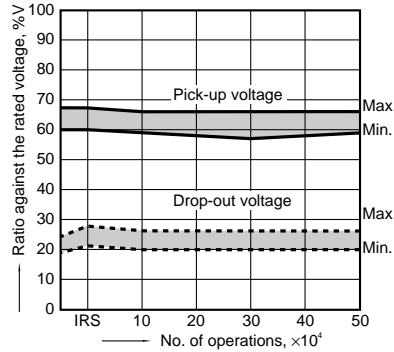

Change of contact resistance  
 (mounting by IRS method)

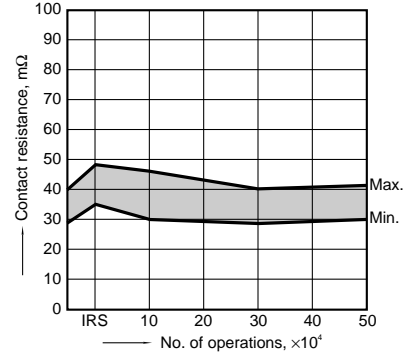

**For Cautions for Use, see Page 178 and 179.**

# T-Series Relays

## T series Cautions for Use

### 1. Coil operating power

Pure DC current should be applied to the coil. The wave form should be rectangular. If it includes ripple, the ripple factor should be less than 5%.

However, check it with the actual circuit since the characteristics may be slightly different.

The nominal operating voltage should be applied to the coil for more than 10 ms to set/reset the latching type relay.

### 2. Coil connection

When connecting coils, refer to the wiring diagram to prevent mis-operation or malfunction.

### 3. External magnetic field

Since T-Series relays are highly sensitive polarized relays, their characteristics will be affected by a strong external magnetic field.

Avoid using the relay under that conditions.

### 4. Conditions for operation, transport and storage

1) Ambient temperature, humidity, and atmospheric pressure during usage, transport, and storage of the relay:

#### TX(-SMD)/TX-D(-SMD)/TQ-SMD

(1) Temperature:

-40 to +85°C -40 to +185°F.

The temperature range is -40 to +70°C -40 to +158°F for the packaged relay.

#### TX-S(-SMD)

(1) Temperature:

-40 to +70°C -40 to +158°F for the package/non-package relay.

#### TQ/TF/TN/TK

(1) Temperature: -40 to +70°C -40 to +158°F

The temperature range is -40 to +60°C -40 to +140°F for the packaged relay.

(2) Humidity: 5 to 85% R.H.

(Avoid freezing and condensation.)

The humidity range varies with the temperature.

Use within the range indicated in the graph below.

(3) Atmospheric pressure: 86 to 106 kPa

#### Temperature and humidity range for usage, transport, and storage:

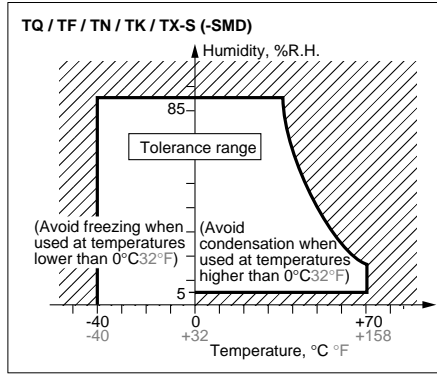
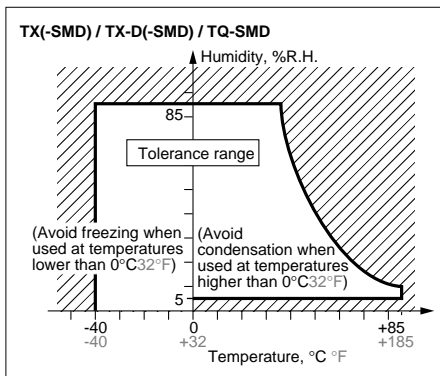

### 2) Condensation

Condensation forms when there is a sudden change in temperature under high temperature, high humidity conditions. Condensation will cause deterioration of the relay insulation.

### 3) Freezing

Condensation or other moisture may freeze on the relay when the temperature is lower than 0°C 32°F.

This causes problems such as sticking of movable parts or operational time lags.

### 4) Low temperature, low humidity environments

The plastic becomes brittle if the relay is exposed to a low temperature, low humidity environment for long periods of time.

### 5. M.B.B. contact relays

A small OFF time may be generated by the contact bounce during contact switching. Check the actual circuit carefully. If the relay is dropped accidentally, check the appearance and characteristics including M.B.B. time before use.

### 6. Packing style

1) Tube orientation for both standard through hole terminal type (including self-clinching type) and surface-mount terminal type.

The relay is packed in a tube with the relay orientation mark on the left side, as shown in the figure below.

Take note of the relay orientation when mounting relays on the printed circuit board.

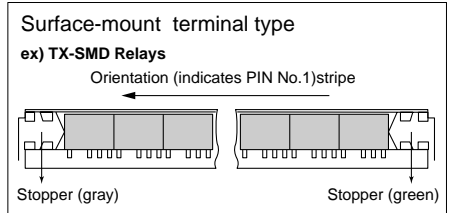
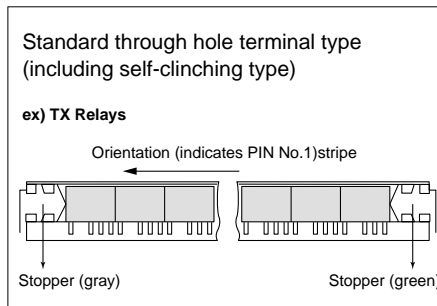

### (2) Tape and reel packing (surface-mount terminal type)

#### (1) Tape dimensions

##### 1. TX/TX-D/TX-S-SMD Relays

#### (i) SA type

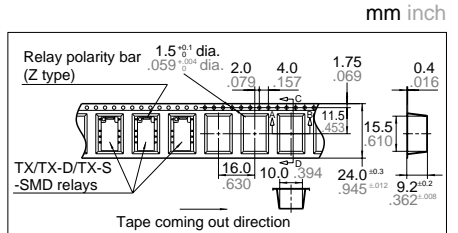

#### (ii) SL type

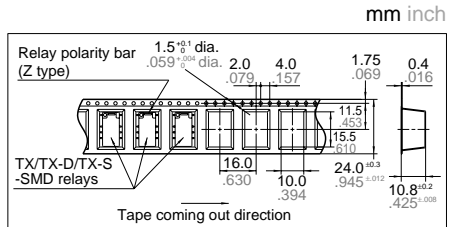

#### (iii) SS type

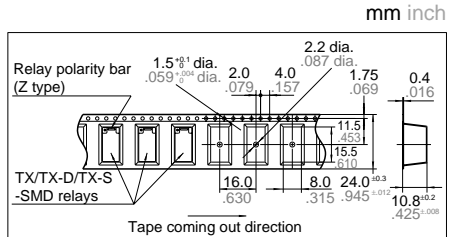

### 2. TQ-SMD Relays

#### (i) SA type

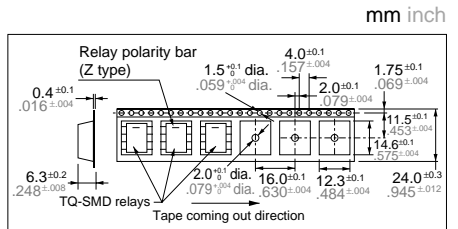

#### (ii) SL, SS type

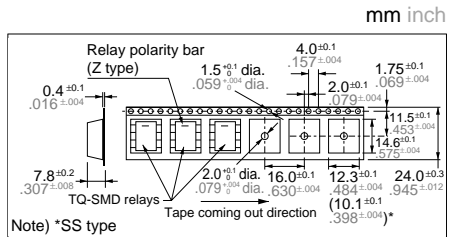

(2) Dimensions of plastic reel  
 (i) TX/TX-D/TX-S-SMD Relays

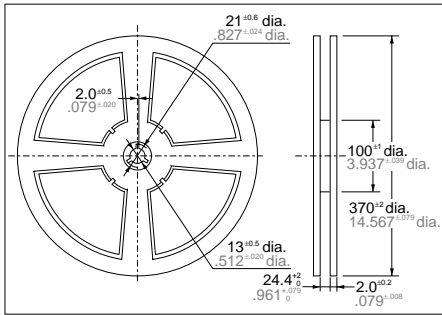

(ii) TQ-SMD Relays

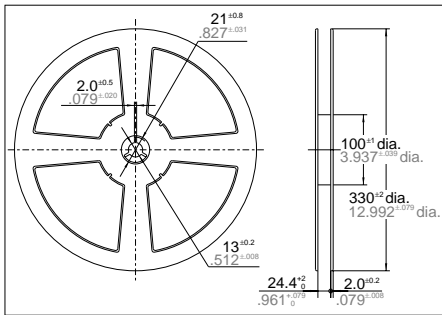

**7. Automatic insertion**

To maintain the internal function of the relay, the chucking pressure should not exceed the values below.

1) TX(-SMD)/TX-D(-SMD)/TQ/TF

Chucking pressure in the direction A:

4.9 N {500 g} or less

Chucking pressure in the direction B:

9.8 N {1 kg} or less

Chucking pressure in the direction C:

9.8 N {1 kg} or less

TX(-SMD)/TX-D(-SMD)/TX-S(-SMD)

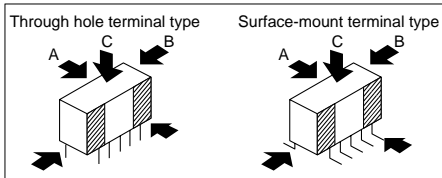

TQ

TF

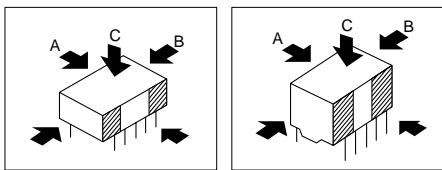

Please chuck the portion.

Avoid chucking the center of the relay.

2) TQ-SMD

Chucking pressure in the direction A:

9.8 N {1 kg} or less

Chucking pressure in the direction B:

9.8 N {1 kg} or less

Mounting pressure in the direction C:

9.8 N {1 kg} or less

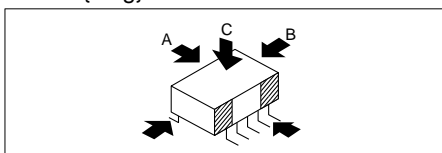

Please chuck the portion.

Avoid chucking the center of the relay.

3) TN

Chucking pressure in the direction A:

9.8 N {1 kg} or less

Chucking pressure in the direction B:

9.8 N {1 kg} or less

Chucking pressure in the direction C:

4.9 N {500 g} or less

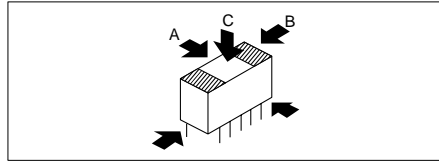

Please chuck the portion.

Avoid chucking the center of the relay.

4) TK

Chucking pressure\* in the direction A:

9.8 N {1 kg} or less

Chucking pressure\* in the direction B:

29.4 N {3 kg} or less

Chucking pressure\* in the direction C:

9.8 N {1 kg} or less

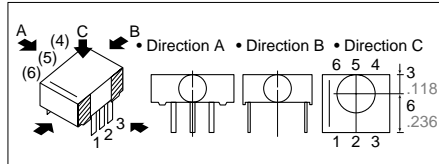

Please chuck the portion.

Avoid chucking the center of the relay.

\*Value of chucking pressure is shown by the value of weight pressed on the portion(4 mm dia.)

**8. Soldering**

1) Preheat according to the following conditions.

Temperature	100°C 212°F or less
Time	Within approx. 1 minute

When soldering standard PC board terminals or self-clinching terminals, soldering should be done at 250°C 482°F within 5 sec.

2) When soldering surface-mount terminals, the following conditions are recommended.

(1) IR (Infrared reflow) soldering method

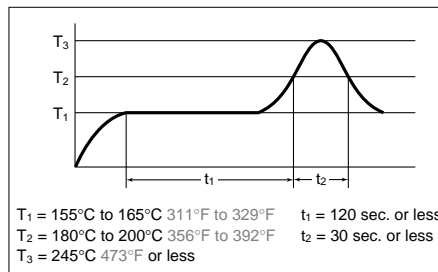

(2) Vapor phase soldering method

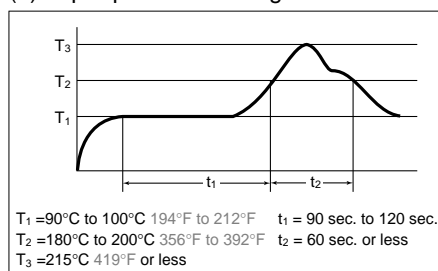

(3) Soldering iron method

Tiptemperature: 280°C to 300°C 536°F to 572°C

Wattage: 30 to 60 W

Soldering time: within 5 sec.

(4) Other soldering methods

Check mounting conditions before using other soldering methods (hot-air, hot plate, pulse heater, etc.).

**Remarks**

The temperature profile indicates the temperature of the soldered terminal on the surface of the PC board.

The ambient temperature may increase excessively.

Check the temperature under mounting conditions.

The conditions for the infrared reflow soldering apply when preheating using the VPS method.

**9. Cleaning**

In automatic cleaning, cleaning with the boiling method is recommended. Avoid ultrasonic cleaning which subject the relay to high frequency vibrations. It may cause the contacts to stick.

It is recommended that a fluorinated hydrocarbon or other alcoholic solvents be used.

**10. Others**

1) If in error the relay has been dropped, the appearance and characteristics should be checked before use without fail.

2) The cycle lifetime is defined under the standard test condition specified in the JIS\* C 5442-1986 standard (temperature 15 to 35°C 59 to 95°F, humidity 25 to 85%). Check this with the real device as it is affected by coil driving circuit, load type, activation frequency, activation phase, ambient conditions and other factors.

3) For secure operations, the voltage applied to the coil should be nominal voltage. In addition, please note that pick-up and drop-out voltage will vary according to the ambient temperature and operation conditions.

4) Latching relays are shipped from the factory in the reset state. A shock to the relay during shipping or installation may cause it to change to the set state.

Therefore, it is recommended that the relay be used in a circuit which initializes the relay to the required state (set or reset) whenever the power is turned on.

5) Check the ambient conditions when storing or transporting the relays and devices containing the relays. Freezing or condensation may occur in the relay, causing functional damage. Avoid subjecting the relays to heavy loads, or strong vibration and shocks.

\*Japanese Industrial Standards