

# NAIS

## FLAT/VERTICAL TYPE HIGH POWER BIFURCATED CONTACT

# NC-RELAYS

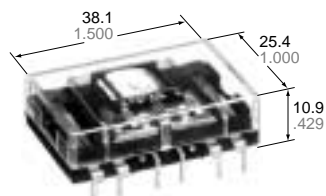

4C Flat type

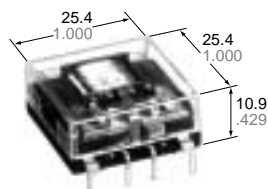

2C Flat type

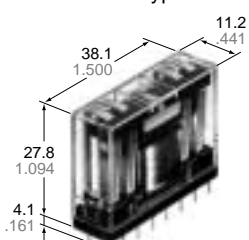

4C Vertical type (PC board)

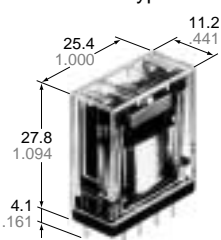

2C Vertical type (PC board)

mm inch

## FEATURES

- Space saver — Flat series and vertical series
- High contact reliability due to bifurcated contacts  
— 2C: 5 A 250 V AC, 4C: 5 A 125 V AC, 4 A 250 V AC
- Latching types available
- Low operating power  
— 2C: 200 mW, 4C: 400 mW (Single side stable)
- Soldering flux inflow prevented by terminal location
- Amber sealed types available
- High breakdown voltage for transient protection  
— 1,000 Vrms between open contacts, contact sets

## SPECIFICATIONS

### Contacts

| Types   |                                 | Standard  | Amber sealed  |
|---|---------------------------------|---|---|
| Arrangement   |                                 | 2 Form C, 4 Form C  |   |
| Initial contact resistance, max. (By voltage drop 6 V DC 1 A) |                                 | 50 mOhm   |   |
| Rating (resistive load)                                       | Max. switching power            | 2C: 1,250 VA 150 W<br>4C: 1,000 VA 150 W                            | 2C: 750 VA 150 W<br>4C: 500 VA 150 W                                |
|   | Max. switching voltage          | 250 V AC  |   |
|   | Max. switching current          | 5 A   |   |
|   | Max. switching carrying current | 5 A   |   |
|   | Min. switching power            | 100 mA 1 V DC   |   |
| Expected life (minimum)                                       | 2C                              | 10 <sup>5</sup> at 5 A 250 V AC<br>5x10 <sup>5</sup> at 5 A 30 V DC | 10 <sup>5</sup> at 3 A 250 V AC<br>5x10 <sup>5</sup> at 5 A 30 V DC |
|   | 4C                              | 10 <sup>5</sup> at 4 A 250 V AC<br>5x10 <sup>5</sup> at 5 A 30 V DC | 10 <sup>5</sup> at 2 A 250 V AC<br>5x10 <sup>5</sup> at 5 A 30 V DC |
| Contact material  |                                 | Gold-clad silver nickel   |   |

### Coil (Polarized) (at 25°C 77°F)

|                             |                        | Up to 48 V DC    | 110 V DC |
|-----------------------------|------------------------|------------------|----------|
| Minimum operating power     | 2 C single side stable | Approx. 200 mW   | 500 mW   |
|                             | 4 C single side stable | Approx. 400 mW   | 500 mW   |
| Nominal operating power     | 2 C single side stable | Approx. 360 mW   | 900 mW   |
|                             | 4 C single side stable | Approx. 720 mW   | 900 mW   |
| Minimum set and reset power | 2 C 2 coil latching    | Approx. 450 mW   |          |
|                             | 4 C 2 coil latching    | Approx. 900 mW   |          |
| Nominal set and reset power | 2 C 2 coil latching    | Approx. 800 mW   |          |
|                             | 4 C 2 coil latching    | Approx. 1,600 mW |          |

### Characteristics (at 25°C 77°F 50% Relative humidity)

|  |                                     |  |   |
|--|-------------------------------------|--|---|
| Max. operating speed   |                                     | 180 cpm  |   |
| Initial insulation resistance  |                                     | Min. 100 MOhm at 500 V DC  |   |
| Initial breakdown voltage*1  | Between open contacts, contact sets | 1,000 Vrms   |   |
|  | Between contacts and coil           | 2,000 Vrms   |   |
| Operate time (at nominal voltage)  |                                     | Approx. 6 ms   |   |
| Release time (at nominal voltage)  |                                     | Approx. 3 ms   |   |
| Operate time (latching) (at nominal voltage)   |                                     | Approx. 6 ms   |   |
| Reset time (latching) (at nominal voltage)   |                                     | Approx. 6 ms   |   |
| Temperature rise (at nominal voltage)  |                                     | Max. 65°C  |   |
| Shock resistance   | Functional*2                        | Min. 98 m/s <sup>2</sup> {10 G}  |   |
|  | Destructive*3                       | Min. 980 m/s <sup>2</sup> {100 G}                                      |   |
| Vibration resistance   | Functional*4                        | 58.8 m/s <sup>2</sup> {6 G}, 10 to 55 Hz at double amplitude of 1 mm   |   |
|  | Destructive                         | 117.6 m/s <sup>2</sup> {12 G}, 10 to 55 Hz at double amplitude of 2 mm |   |
| Conditions for operation, transport and storage*5 (Not freezing and condensing at low temperature) | (Single side stable)                | 2 C  | up to 48 V DC: -40°C to +70°C<br>-40°F to +158°F<br>110 V DC: -40°C to +55°C<br>-40°F to +131°F |
|  |                                     | 4 C  | -40°C to +55°C -40°F to +131°F  |
|  | (2 coil latching)                   | -40°C to +55°C -40°F to +131°F   |   |
| Humidity   |                                     | 5 to 85% R.H.  |   |
| Unit weight  |                                     | 2C/Approx. 16 g .56 oz<br>4C/Approx. 18 g .63 oz                       |   |

### Remarks

- \* Specifications will vary with foreign standards certification ratings.  
 \*1 Detection current: 10 mA  
 \*2 Half-wave pulse of sine wave: 11ms; detection time: 10µs  
 \*3 Half-wave pulse of sine wave: 6ms  
 \*4 Detection time: 10µs  
 \*5 Refer to 5. Conditions for operation, transport and storage mentioned in AMBIENT ENVIRONMENT (Page 61).

## TYPICAL APPLICATIONS

Use NC Relays for power control up to 5 A or —  
 Tape recorders, temperature controls, video tape recorders  
 Telecommunications equipment, measuring controls, copiers  
 Date processing equipment, computer peripherals  
 Automatic vendors, copiers, automatic storage controls, N.C. machines

## ORDERING INFORMATION

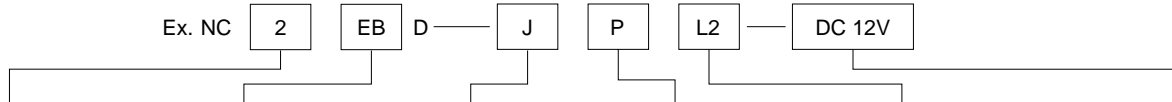

| Contact arrangement        | Type classification                         | Housing                                | Mounting method                      | Operating function                             | Coil voltage               |
|----------------------------|---|--|--------------------------------------|--|----------------------------|
| 2: 2 Form C<br>4: 4 Form C | Nil: Standard type<br>EB: Amber sealed type | Nil: Vertical series<br>J: Flat series | Nil: Plug-in<br>P: PC board terminal | Nil: Single side stable<br>L2: 2 coil latching | DC 5, 6, 12, 24, 48, 110 V |

- (Notes) 1. Flat series are available in PC board terminal types only.  
 2. For VDE recognized type, add suffix VDE.  
 3. Standard packing Carton: 20 pcs. Case: 200 pcs.  
 4. UL/CSA, approved type is standard.

## TYPE AND COIL DATA (at 20°C 68°F) (Coil data for Amber sealed types are same as those for standard types.)

### 2 Form C Single side stable

| Flat series    | Vertical series   |               | Coil voltage, V DC |                        |                         | Coil resistance, Ohm (±10%) | Nominal operating power, mW |
|----------------|-------------------|---------------|--------------------|------------------------|-------------------------|-----------------------------|-----------------------------|
|                | PC board terminal | Plug-in       | PC board terminal  | Pick-up voltage (max.) | Drop-out voltage (min.) |                             |                             |
| NC2D-JP-DC5V   | NC2D-DC5V         | NC2D-P-DC5V   | 4.0                | 0.5                    | 6.75                    | 69.4                        | 360                         |
| NC2D-JP-DC6V   | NC2D-DC6V         | NC2D-P-DC6V   | 4.8                | 0.6                    | 8.1                     | 100                         |                             |
| NC2D-JP-DC12V  | NC2D-DC12V        | NC2D-P-DC12V  | 9.6                | 1.2                    | 16.2                    | 400                         |                             |
| NC2D-JP-DC24V  | NC2D-DC24V        | NC2D-P-DC24V  | 19.2               | 2.4                    | 32.4                    | 1,600                       |                             |
| NC2D-JP-DC48V  | NC2D-DC48V        | NC2D-P-DC48V  | 38.4               | 4.8                    | 64.8                    | 6,400                       |                             |
| NC2D-JP-DC110V | NC2D-DC110V       | NC2D-P-DC110V | 88.0               | 11.0                   | 121                     | 13,500                      | 900                         |

### 2 Form C 2 coil latching

| Flat series      | Vertical series   |                 | Coil voltage, V DC |                        |                      | Coil resistance, Ohm (±10%) | Nominal operating power, mW |
|------------------|-------------------|-----------------|--------------------|------------------------|----------------------|-----------------------------|-----------------------------|
|                  | PC board terminal | Plug-in         | PC board terminal  | Pick-up voltage (max.) | Reset voltage (max.) |                             |                             |
| NC2D-JPL2-DC5V   | NC2D-L2-DC5V      | NC2D-PL2-DC5V   | 4.0                | 4.0                    | 5.5                  | 31.3                        | 800                         |
| NC2D-JPL2-DC6V   | NC2D-L2-DC6V      | NC2D-PL2-DC6V   | 4.8                | 4.8                    | 6.6                  | 45.0                        |                             |
| NC2D-JPL2-DC12V  | NC2D-L2-DC12V     | NC2D-PL2-DC12V  | 9.6                | 9.6                    | 13.2                 | 180                         |                             |
| NC2D-JPL2-DC24V  | NC2D-L2-DC24V     | NC2D-PL2-DC24V  | 19.2               | 19.2                   | 26.4                 | 720                         |                             |
| NC2D-JPL2-DC48V  | NC2D-L2-DC48V     | NC2D-PL2-DC48V  | 38.4               | 38.4                   | 52.8                 | 2,880                       |                             |
| NC2D-JPL2-DC110V | NC2D-L2-DC110V    | NC2D-PL2-DC110V | 88.0               | 88.0                   | 121                  | 15,125                      |                             |

### 4 Form C Single side stable

| Flat series    | Vertical series   |               | Coil voltage, V DC |                        |                         | Coil resistance, Ohm (±10%) | Nominal operating power, mW |
|----------------|-------------------|---------------|--------------------|------------------------|-------------------------|-----------------------------|-----------------------------|
|                | PC board terminal | Plug-in       | PC board terminal  | Pick-up voltage (max.) | Drop-out voltage (min.) |                             |                             |
| NC4D-JP-DC5V   | NC4D-DC5V         | NC4D-P-DC5V   | 4.0                | 0.5                    | 5.5                     | 34.7                        | 720                         |
| NC4D-JP-DC6V   | NC4D-DC6V         | NC4D-P-DC6V   | 4.8                | 0.6                    | 6.6                     | 50                          |                             |
| NC4D-JP-DC12V  | NC4D-DC12V        | NC4D-P-DC12V  | 9.6                | 1.2                    | 13.2                    | 200                         |                             |
| NC4D-JP-DC24V  | NC4D-DC24V        | NC4D-P-DC24V  | 19.2               | 2.4                    | 26.4                    | 800                         |                             |
| NC4D-JP-DC48V  | NC4D-DC48V        | NC4D-P-DC48V  | 38.4               | 4.8                    | 52.8                    | 3,200                       |                             |
| NC4D-JP-DC110V | NC4D-DC110V       | NC4D-P-DC110V | 88.0               | 11.0                   | 121                     | 13,500                      | 900                         |

4 Form C 2 coil latching

| Flat series      | Vertical series   |                 | Coil voltage, V DC |                        |                      | Coil resistance, Ohm (±10%) | Nominal operating power, mW |
|------------------|-------------------|-----------------|--------------------|------------------------|----------------------|-----------------------------|-----------------------------|
|                  | PC board terminal | Plug-in         | PC board terminal  | Pick-up voltage (max.) | Reset voltage (max.) |                             |                             |
| NC4D-JPL2-DC5V   | NC4D-L2-DC5V      | NC4D-PL2-DC5V   | 4.0                | 4.0                    | 5.5                  | 15.6                        | 1,600                       |
| NC4D-JPL2-DC6V   | NC4D-L2-DC6V      | NC4D-PL2-DC6V   | 4.8                | 4.8                    | 6.6                  | 22.5                        |                             |
| NC4D-JPL2-DC12V  | NC4D-L2-DC12V     | NC4D-PL2-DC12V  | 9.6                | 9.6                    | 13.2                 | 90                          |                             |
| NC4D-JPL2-DC24V  | NC4D-L2-DC24V     | NC4D-PL2-DC24V  | 19.2               | 19.2                   | 26.4                 | 360                         |                             |
| NC4D-JPL2-DC48V  | NC4D-L2-DC48V     | NC4D-PL2-DC48V  | 38.4               | 38.4                   | 52.8                 | 1,440                       |                             |
| NC4D-JPL2-DC110V | NC4D-L2-DC110V    | NC4D-PL2-DC110V | 88.0               | 88.0                   | 121                  | 7,560                       |                             |

Notes:

- Two coil latching relay 4C series are for intermittent operation only. Power should be applied to coil continuously for no more than two minutes.
- Coil resistance is the measured value at a coil temperature of 20°C. Compensate coil resistance by plus or minus 0.4% for each degree (°C) of coil temperature change.
- "Maximum allowable voltage" is that value at maximum contact rating and maximum ambient temperature. The graph shown in the data describes the inter-relationship; care should be taken to prevent the total of ambient temperature and the coil temperature rise from exceeding 120°C.

DIMENSIONS

mm inch

Flat series

2C single side stable (NC2D-JP)

Standard type

General tolerance: ±0.5 ±.020

Amber sealed type

General tolerance: ±0.5 ±.020

PC board pattern (Copper-side view)

Tolerance: ±0.1 ±.004

Schematic (Top view)

Deenergized position

2C 2 coil latching (NC2D-JPL2)

Standard type

General tolerance: ±0.5 ±.020

Amber sealed type

General tolerance: ±0.5 ±.020

PC board pattern (Copper-side view)

Tolerance: ±0.1 ±.004

Schematic (Top view)

Diagram shows the "reset" position when terminals 3 and 6 are energized. Energize terminals 4 and 5 to transfer contacts.

# NC

4C single side stable  
(NC4D-JP)

mm inch

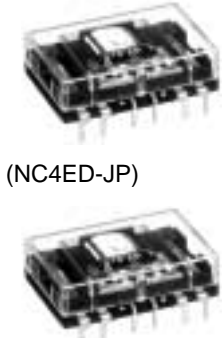

(NC4ED-JP)

Standard type

Amber sealed type

PC board pattern (Copper-side view)

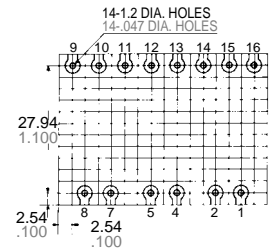
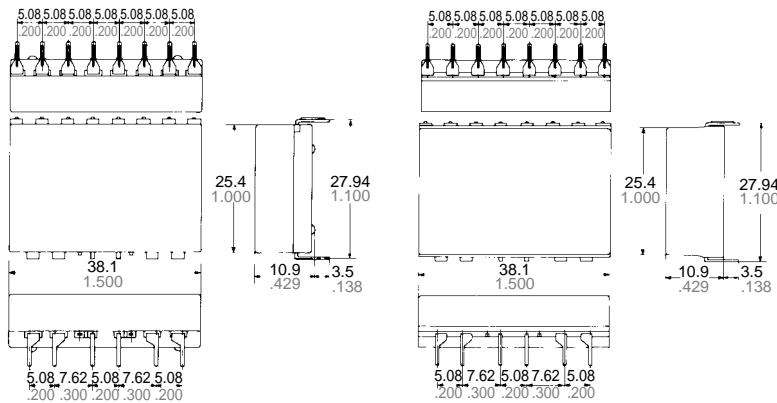

Tolerance:  $\pm 0.1 \pm .004$

Schematic (Top view)

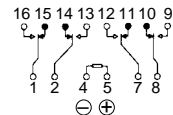

Deenergized position

General tolerance:  $\pm 0.5 \pm .020$

4C 2 coil latching  
(NC4D-JPL2)

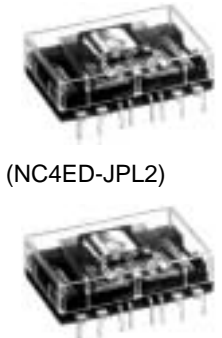

(NC4ED-JPL2)

Standard type

Amber sealed type

PC board pattern (Copper-side view)

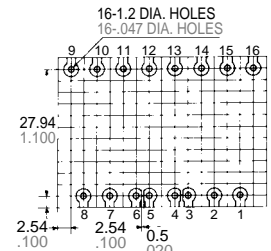
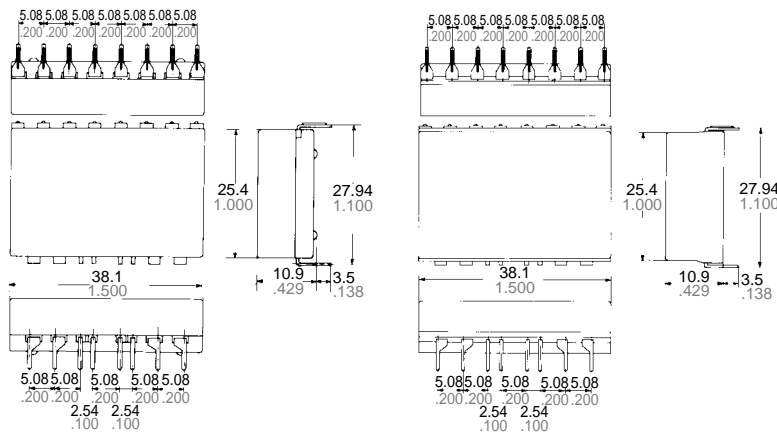

Tolerance:  $\pm 0.1 \pm .004$

Schematic (Top view)

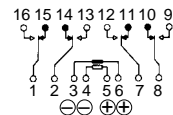

Diagram shows the "reset" position when terminals 3 and 6 are energized. Energize terminals 4 and 5 to transfer contacts.

General tolerance:  $\pm 0.5 \pm .020$

## Slim series

### PC board series

2C single side stable  
(NC2D-P)



(NC2ED-PL2)

Standard type

Amber sealed type

PC board pattern (Copper-side view)

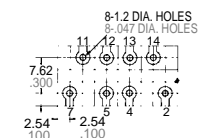
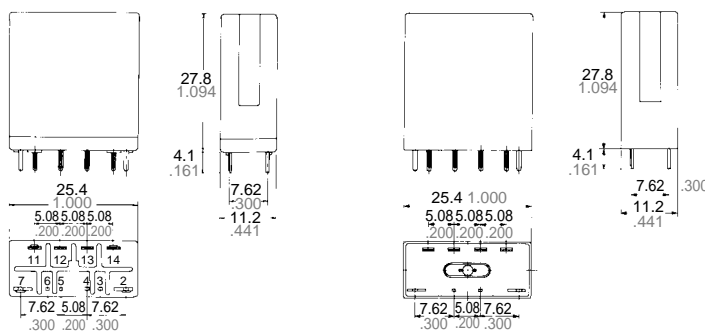

Tolerance:  $\pm 0.1 \pm .004$

Schematic (Bottom view)

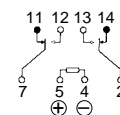

Deenergized position

General tolerance:  $\pm 0.5 \pm .020$

2C 2 coil latching  
(NC2D-PL2)



(NC2ED-P)



Standard type

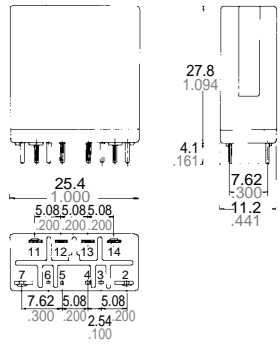

Amber sealed type

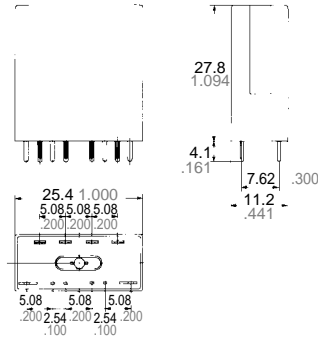

PC board pattern (Copper-side view)

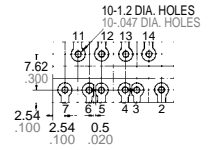

Tolerance:  $\pm 0.1 \pm .004$

Schematic (Bottom view)

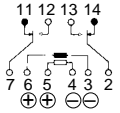

General tolerance:  $\pm 0.5 \pm .020$

Diagram shows the "reset" position when terminals 3 and 6 are energized. Energize terminals 4 and 5 to transfer contacts.

4C single side stable  
(NC4D-P)



(NC4ED-P)



Standard type

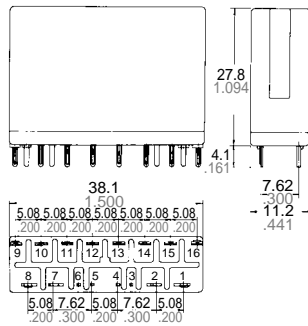

Amber sealed type

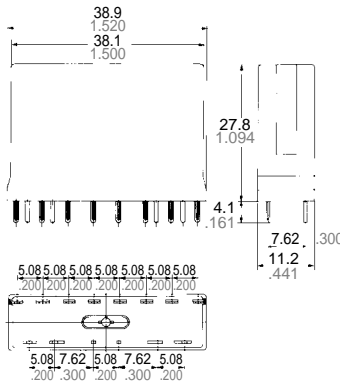

PC board pattern (Copper-side view)

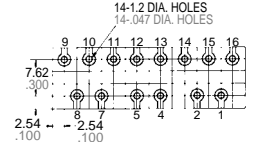

Tolerance:  $\pm 0.1 \pm .004$

Schematic (Bottom view)

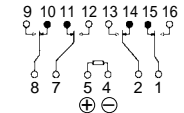

General tolerance:  $\pm 0.5 \pm .020$

Deenergized position

4C 2 coil latching  
(NC4D-PL2)



(NC4ED-PL2)



Standard type

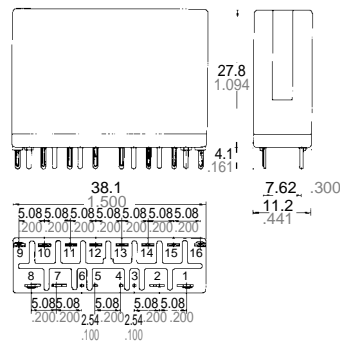

Amber sealed type

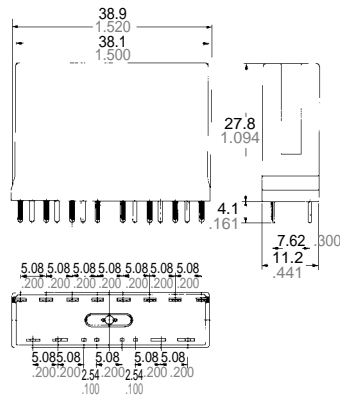

PC board pattern (Copper-side view)

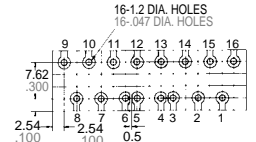

Tolerance:  $\pm 0.1 \pm .004$

Schematic (Bottom view)

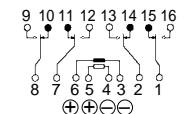

General tolerance:  $\pm 0.5 \pm .020$

Diagram shows the "reset" position when terminals 3 and 6 are energized. Energize terminals 4 and 5 to transfer contacts.

# NC

## Slim series Plug-in series

mm inch

2C single side stable  
(NC2D)

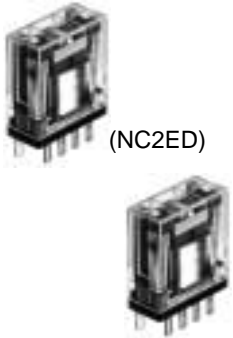

Standard type

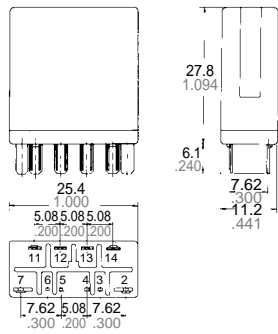

Amber sealed type

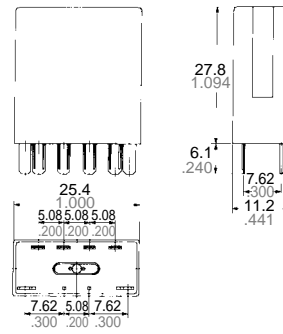

Schematic (Bottom view)

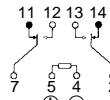

Deenergized position

General tolerance:  $\pm 0.5 \pm .020$

2C 2 coil latching  
(NC2D-L2)



Standard type

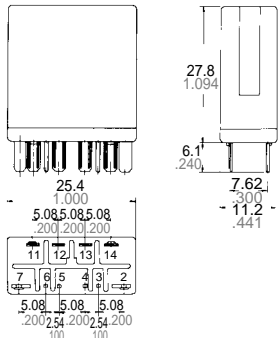

Amber sealed type

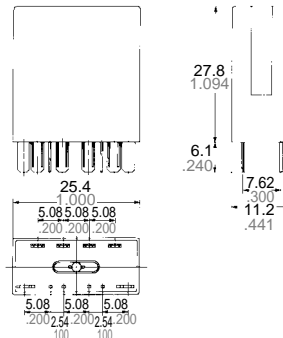

Schematic (Bottom view)

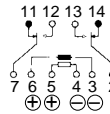
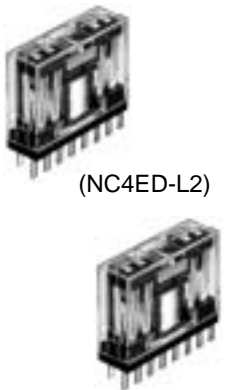

Diagram shows the "reset" position when terminals 3 and 6 are energized. Energize terminals 4 and 5 to transfer contacts.

General tolerance:  $\pm 0.5 \pm .020$

4C single side stable  
(NC4D)



Standard type

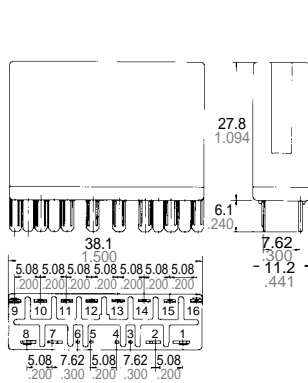

Amber sealed type

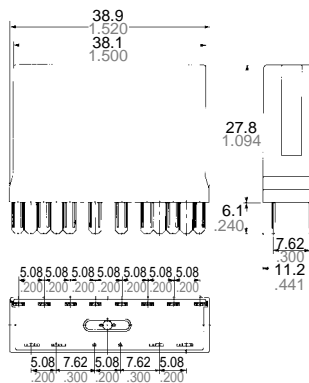

Schematic (Bottom view)

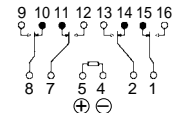

Deenergized position

General tolerance:  $\pm 0.5 \pm .020$

4C 2 coil latching  
(NC4D-L2)

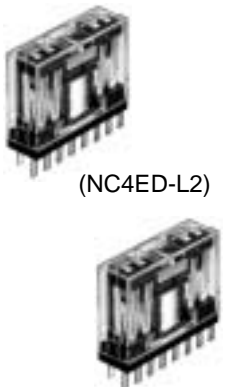

Standard type

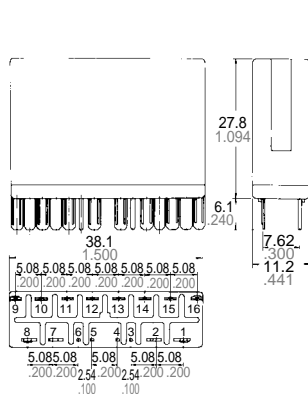

Amber sealed type

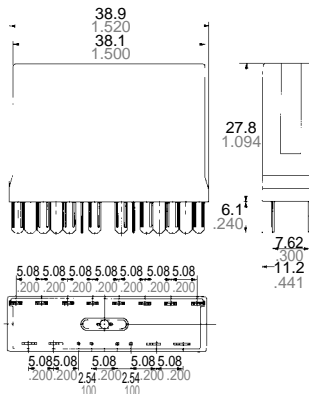

Schematic (Bottom view)

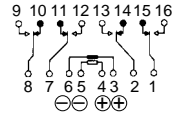

Diagram shows the "reset" position when terminals 3 and 6 are energized. Energize terminals 4 and 5 to transfer contacts.

General tolerance:  $\pm 0.5 \pm .020$

# Schematic

— Energize relays only in the polarities shown —

## 1. Single side stable

Same operation as conventional magnetic relays.

Contacts will transfer only when coil is energized under indicated polarity.

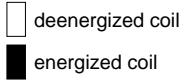

2C

4C

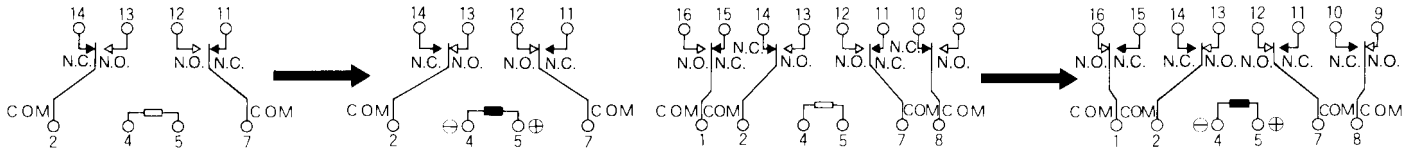

## 2. 2 coil latching

Contacts will transfer only when coil is energized under indicated polarity.

Once transferred, contacts remain in that position even with power off until opposite coil is energized at indicated polarity.

2C

4C

2C

4C

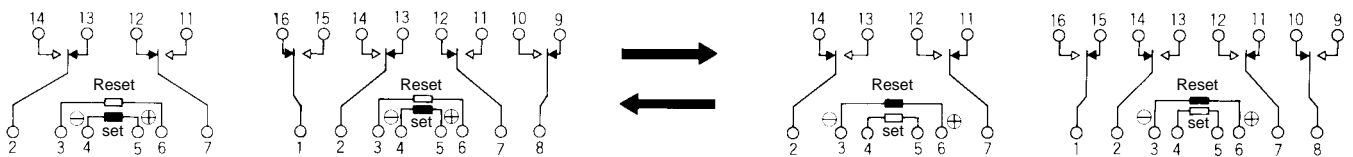

Diagrams show the "set" position when terminals 4 (-) and 5 (+) are energized. When the coil current is switched off, these contacts remain in "make" position.

Energize terminals 3 (-) and 6 (+) to transfer the contacts. Diagrams show the "reset" position when terminals 3 (-) and 6 (+) are energized.

Energize terminals 4 (-) and 5 (+) to transfer the contacts.

# REFERENCE DATA

## Standard type

1.-(1) Life curve  
DC load (2C, 4C)

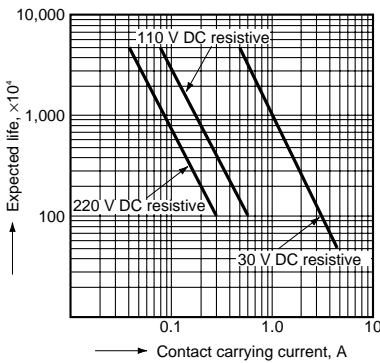

AC load (2C)

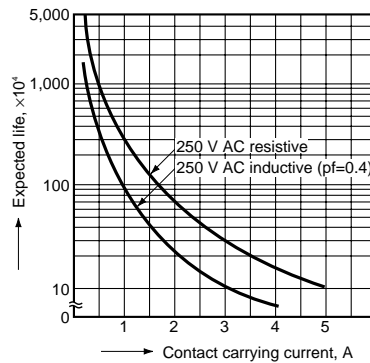

AC load (4C)

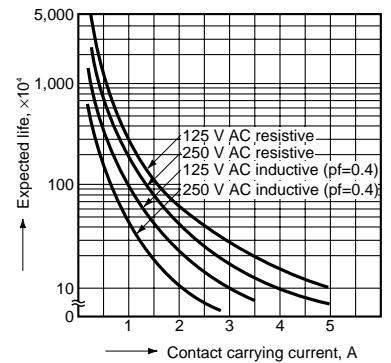

## 2.-(1) Temperature rise characteristics for single side stable

Measured portion: Inside the coil

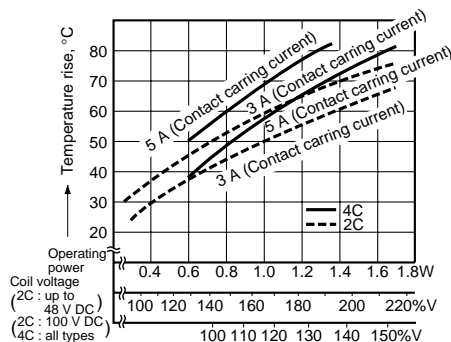

## 2.-(2) Temperature rise characteristics for 2 coil latching

Measured portion: Inside the coil

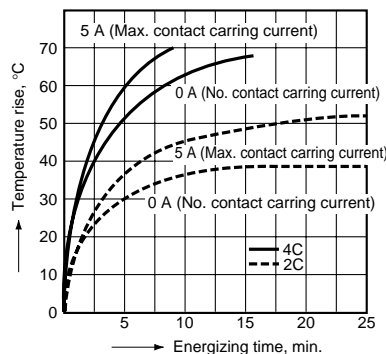

### 3. Operate time for single side stable

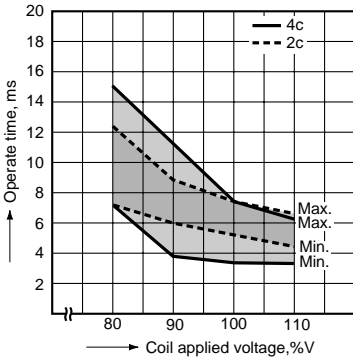

### 4. Release time for single side stable

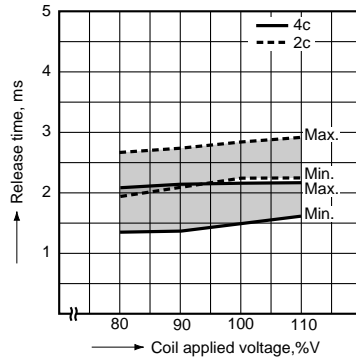

### 5. Rate of change of pick-up and drop-out voltage 2 Form C single side stable

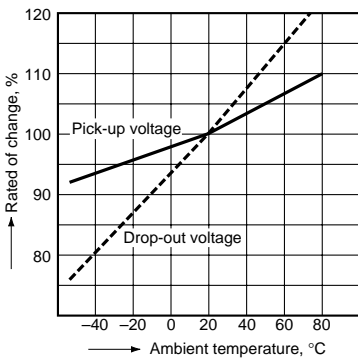

### 4 Form C single side stable

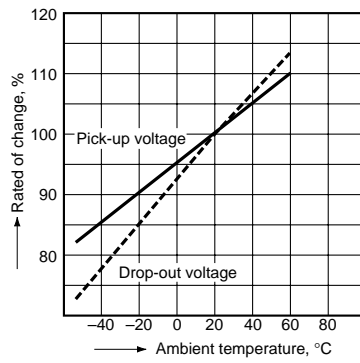

### 6.-(1) Ambient temperature vs Max. continuous voltage

Sample: NC2D-P-DC24 V (2c slim single side stable)

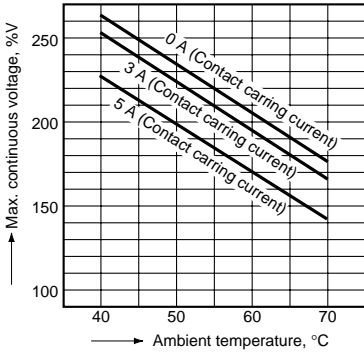

### 6.-(2) Ambient temperature vs Max. continuous voltage

Sample: NC2D-P-DC110 V (2c slim single side stable), NC4D-P-DC24 V (4c slim single side stable)

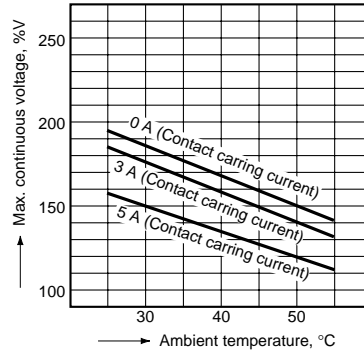

## ACCESSORIES

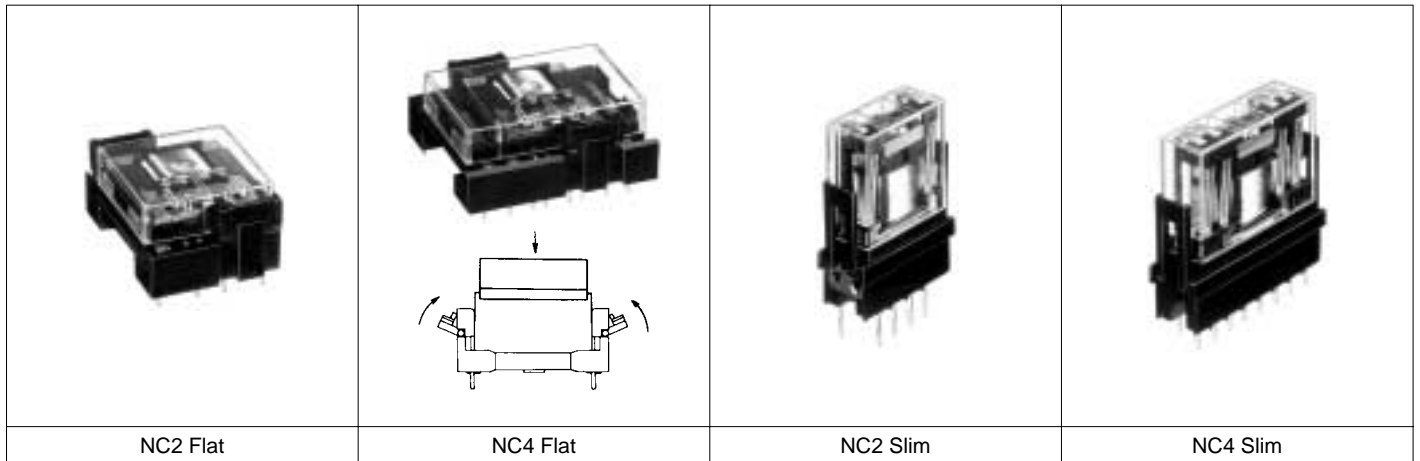

Sockets incorporate a spring clip at each end permitting single "snap-in" attachment to chassis or panels - no screws

necessary. Relays are held firmly in the socket by clips integrally molded into the socket.

## TYPES

For Flat series

| Part No.  | Terminals | Mating relay |
|-----------|-----------|--------------|
| NC2-JPS   | P/C board | NC2D-JP      |
| NC4-JPS   | P/C board | NC4D-JP      |
| NC2-JPL2S | P/C board | NC2D-JPL2    |
| NC4-JPL2S | P/C board | NC4D-JPL2    |

Standard packing:  
Carton: 20 pieces  
Case: 200 pieces

For Slim series

| Part No. | Terminals | Mating relay |
|----------|-----------|--------------|
| NC2-PS   | P/C board | NC2D-P       |
| NC4-PS   | P/C board | NC4D-P       |
| NC2-SS   | Solder    | NC2D         |
| NC4-SS   | Solder    | NC2D         |
| NC2-L2PS | P/C board | NC4D-PL2     |
| NC4-L2PS | P/C board | NC2D-PL2     |
| NC4-L2SS | Solder    | NC2D-L2      |
| NC4-L2SS | Solder    | NC4D-L2      |

## SPECIFICATIONS

|                               |   |
|-------------------------------|---|
| Maximum continuous current    | Flat series: 5 A 250 V AC Slim series: 5 A 250 V AC       |
| Initial breakdown voltage     | 2,000 V AC (Except for coil-coil of L2 types: 1,500 V AC) |
| Initial insulation resistance | 100 MW at 500 V DC  |
| Heat resistance               | 150°C (302°F) for one hour                                |

Caution: Do not insert or remove relays while in the energized condition.

**DIMENSIONS**

mm inch

**Flat series**

NC2-JPS  
NC2-JPL2S

Terminal width: 0.9 .035  
Terminal thickness: 0.4 .016

Terminal portion

PC board pattern  
(copper-side view)

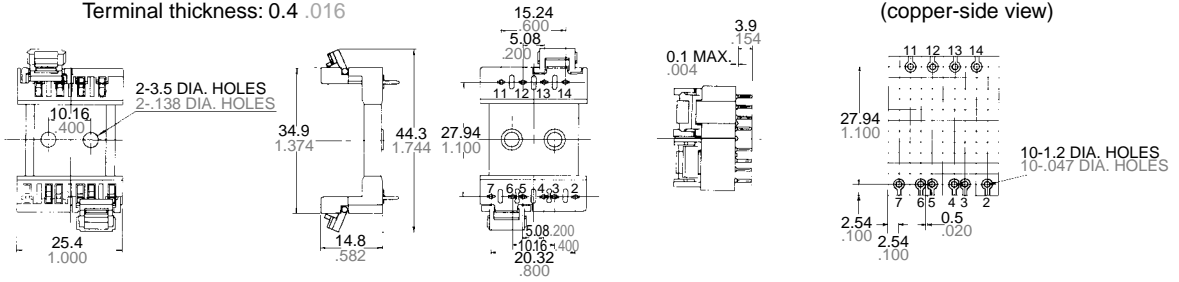

Terminals 3 and 6 excluded for NC2-JPS.

General tolerance:  $\pm 0.5 \pm .020$

Tolerance:  $\pm 0.1 \pm .004$

NC4-JPS  
NC4-JPL2S

Terminal width: 0.9 .035  
Terminal thickness: 0.4 .016

Terminal portion

PC board pattern  
(copper-side view)

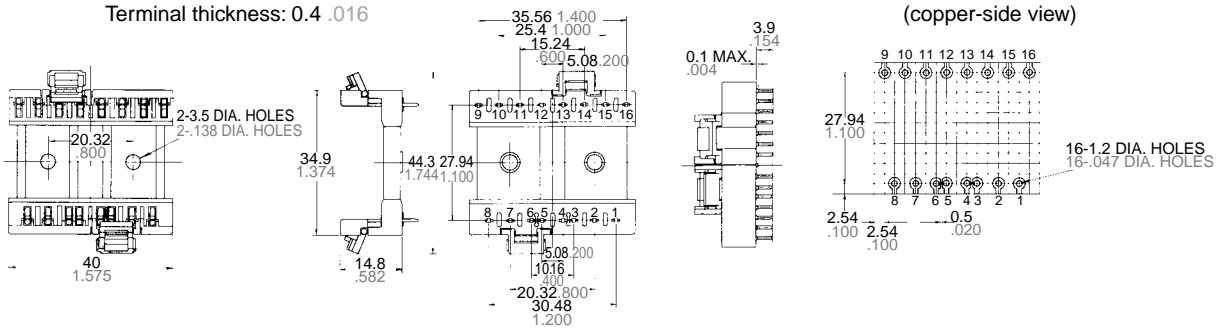

Terminals 3 and 6 excluded for NC4-JPS.

General tolerance:  $\pm 0.5 \pm .020$

Tolerance:  $\pm 0.1 \pm .004$

**Slim series**

NC2-SS  
NC2-L2S

Terminal width: 1.9 .075  
Terminal thickness: 0.4 .016

Chassis cutout

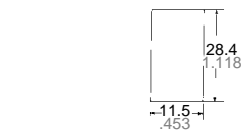
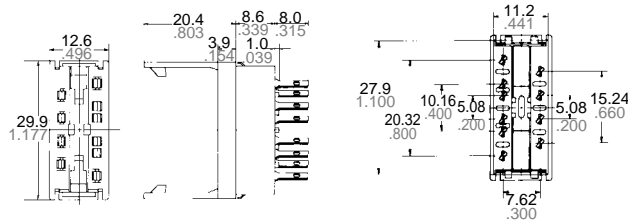

Chassis thickness range: 1.0 to 2.0  
.039 to .079

Terminals 3 and 6 excluded for NC2-SS.

General tolerance:  $\pm 0.5 \pm .020$

NC2-PS  
NC2-L2P

Terminal width: 0.9 .035  
Terminal thickness: 0.4 .016

PC board pattern  
(copper-side view)

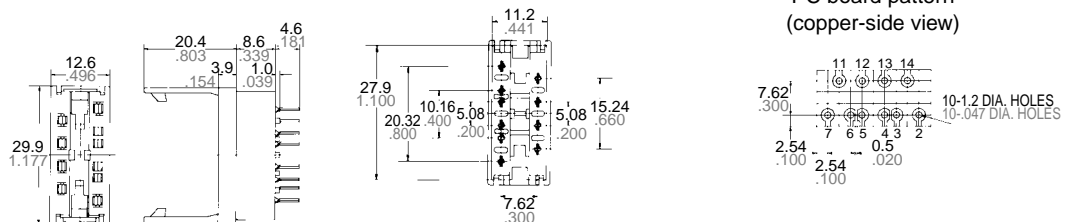

Terminals 3 and 6 excluded for NC2-PS.

General tolerance:  $\pm 0.5 \pm .020$

Tolerance:  $\pm 0.1 \pm .004$

NC4-SS  
NC4-L2S

Terminal width: 1.9 .075  
Terminal thickness: 0.4 .016

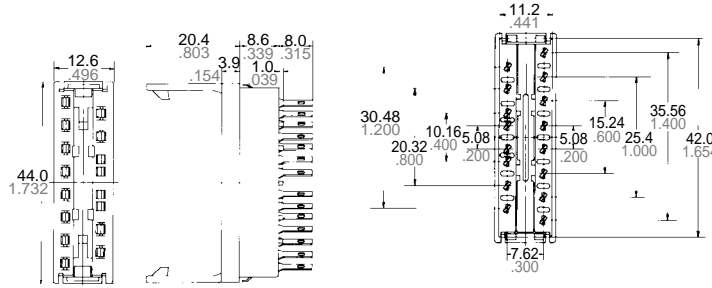

Chassis cutout

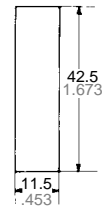

Chassis thickness range: 1.0 to 2.0  
.039 to .079

Terminals 3 and 6 excluded for NC4-SS.

General tolerance:  $\pm 0.5 \pm .020$

NC4-PS  
NC4-L2P

Terminal width: 0.9 .035  
Terminal thickness: 0.4 .016

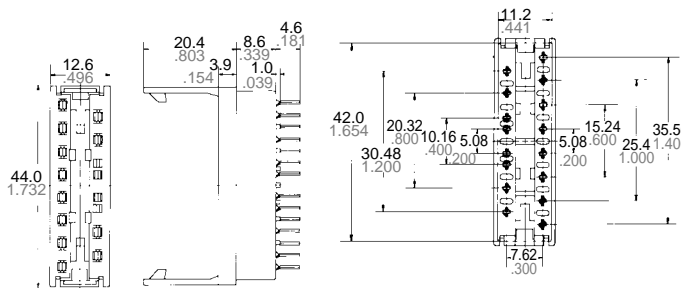

PC board pattern  
(copper-side view)

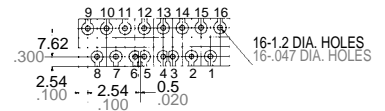

Terminals 3 and 6 excluded for NC4-PS.

General tolerance:  $\pm 0.5 \pm .020$

Tolerance:  $\pm 0.1 \pm .004$

## NOTES

1. To maintain insulation between coils of 2 coil latching series, terminals 5 and 6 for flat series, and terminals 3 and 4 for slim series should be connected to provide common return.

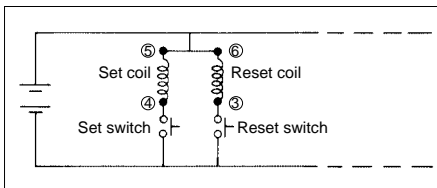

2. 2 coil latching series 4C are for intermittent operation only. Power should be applied to coils continuously for no more than two minutes.

3. When designing printed circuit board patterns, note that:

(1) "Top View" wiring diagram is indicated for the Flat series because terminals can be seen from above.

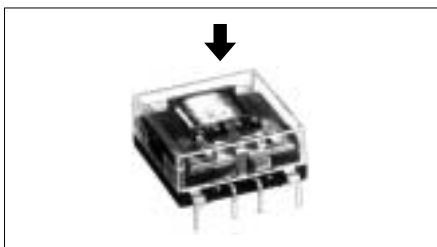

(2) "Bottom View" wiring diagram is indicated for the Slim series because terminals can not be seen from above.



4. When using slim series in close proximity, mount all relays facing the same direction.

Different mounting directions may cause change in the relay characteristics because NC relays are polarized.

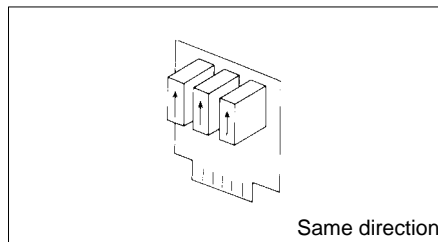

5. Sockets

- (1) When PC board series are used with socket, do not apply loads exceeding 3 A.
- (2) Soldering should be done quickly to avoid damaging the thermoplastic body.
- (3) Insulation will be optimum when wire connections are soldered as shown with all slim sockets.

