

# NAIS

## COMPACT PC BOARD POWER RELAY

# JW RELAYS

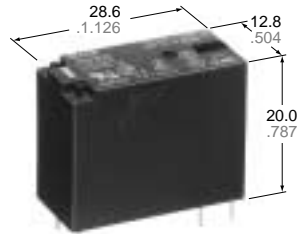

mm inch

## FEATURES

- Miniature package with universal terminal footprint
- High dielectric withstanding for transient protection: 10,000 V surge in  $\mu\text{s}$  between coil and contact
- Sealed construction
- Class B coil insulation types available
- TV rated (TV-5) types available (only for 1 Form A type)
- VDE, TÜV, SEMKO, SEV, FIMKO, TV-5 also approved

## SPECIFICATIONS

### Contact

		Standard type	High capacity type
Arrangement		1 Form A, 1 Form C, 2 Form A, 2 Form C	1 Form A, 1 Form C
Initial contact resistance, max. (By voltage drop 6 V DC 1 A)		100 m $\Omega$	
Contact material		Silver alloy	
Rating (resistive load)	Nominal switch- ing capacity	5 A 250 V AC, 5 A 30 V DC	10 A 250 V AC, 10 A 30 V DC
	Max. switching power	1,250 VA, 150 W	2,500 VA, 300 W
	Max. switching voltage	250 V AC, 30 V DC	
	Max. switching current	5 A	10 A
Expected life (min. ope.)	Mechanical (at 180 cpm)	5 $\times$ 10 <sup>6</sup>	
	Electrical (at 6 cpm) (Resistive load)	10 <sup>5</sup>	

### Coil

Nominal operating power	530 mW
-------------------------	--------

### Remarks

- \* Specifications will vary with foreign standards certification ratings.
- \*<sup>1</sup> Detection current: 10mA
- \*<sup>2</sup> Wave is standard shock voltage of  $\pm 1.2 \times 50\mu\text{s}$  according to JEC-212-1981
- \*<sup>3</sup> Excluding contact bounce time
- \*<sup>4</sup> Half-wave pulse of sine wave: 11ms; detection time: 10 $\mu\text{s}$
- \*<sup>5</sup> Half-wave pulse of sine wave: 6ms
- \*<sup>6</sup> Detection time: 10 $\mu\text{s}$
- \*<sup>7</sup> Refer to 5. Conditions for operation, transport and storage mentioned in AMBIENT ENVIRONMENT (Page 24).
- \*<sup>8</sup> When using relays in a high ambient temperature, consider the pick-up voltage rise due to the high temperature (a rise of approx. 0.4% V for each 1°C 33.8°F with 20°C 68°F as a reference) and use a coil impressed voltage that is within the maximum allowable voltage range.

### Characteristics

		Standard type	High capacity type
Max. operating speed (at rated load)		6 cpm	
Initial insulation resistance		Min. 1,000 M $\Omega$ at 500 V DC	
Initial breakdown voltage* <sup>1</sup>	Between open contacts	1,000 Vrms for 1 min.	
	Between contacts and coil	5,000 Vrms for 1 min.	
	Between contact sets	3,000 Vrms for 1 min. (2 Form A, 2 Form C)	
Initial surge voltage between contacts and coil* <sup>2</sup>		Min. 10,000 V	
Operate time* <sup>3</sup> (at nominal voltage)		Max. 15 ms	
Release time (without diode)* <sup>3</sup> (at nominal voltage)		Max. 5 ms	
Temperature rise (at 20°C) (at nominal voltage) (with nominal coil voltage and at nominal switching capacity)		1a: max. 39°C 1c, 2a, 2c: max. 55°C (resistance method)	1a: max. 45°C 1c: max. 55°C (resistance method)
Shock resistance	Functional* <sup>4</sup>	Min. 98 m/s <sup>2</sup> {10 G}	
	Destructive* <sup>5</sup>	Min. 980 m/s <sup>2</sup> {100 G}	
Vibration resistance	Functional* <sup>6</sup>	Approx. 98 m/s <sup>2</sup> {10 G}, 10 to 55 Hz at double amplitude of 1.6 mm	
	Destructive	Approx. 117.6 m/s <sup>2</sup> {12 G}, 10 to 55 Hz at double amplitude of 2.0 mm	
Conditions for operation, transport and storage* <sup>7</sup> (Not freezing and condensing at low temperature)	Ambient temp.* <sup>8</sup>	-40°C to +85°C -40°F to +185°F	
	Humidity	5 to 85% R.H.	
Unit weight		Approx. 13 g .46 oz	

## TYPICAL APPLICATIONS

- Home appliances  
TV sets, VCR, Microwave ovens
- Office machines  
Photocopiers, Vending machines
- Industrial equipment  
NC machines, Robots, Temperature controllers

**ORDERING INFORMATION**

Ex. JW 1 F S N B DC5V

Contact arrangement	Contact capacity	Protective construction	Pick-up voltage	Coil insulation class	Coil voltage
1: 1 Form C 1a: 1 Form A 2: 2 Form C 2a: 2 Form A	Nil: Standard (5 A) F: High capacity (10 A)*	S: Sealed type	N: 70% of nominal voltage	Nil: Class E insulation B: Class B insulation	DC 5, 6, 9, 12, 18, 24, 48 V

\*Only for 1 Form A and 1 Form C type

UL/CSA, VDE, SEMKO, FIMKO, SEV approved type is standard.

Notes: 1. When ordering TV rated (TV-5) types, add suffix-TV (available only for 1 Form A type).

2. Standard packing: Carton: 100 pcs. Case: 500 pcs.

**TYPES**

**Standard (5A) types**

Contact arrangement	Coil voltage, V DC	Part No.	Contact arrangement	Coil voltage, V DC	Part No.
1 Form A	5	JW1aSN-DC5V	2 Form A	5	JW2aSN-DC5V
	6	JW1aSN-DC6V		6	JW2aSN-DC6V
	9	JW1aSN-DC9V		9	JW2aSN-DC9V
	12	JW1aSN-DC12V		12	JW2aSN-DC12V
	18	JW1aSN-DC18V		18	JW2aSN-DC18V
	24	JW1aSN-DC24V		24	JW2aSN-DC24V
1 Form C	48	JW1aSN-DC48V	2 Form C	48	JW2aSN-DC48V
	5	JW1SN-DC5V		5	JW2SN-DC5V
	6	JW1SN-DC6V		6	JW2SN-DC6V
	9	JW1SN-DC9V		9	JW2SN-DC9V
	12	JW1SN-DC12V		12	JW2SN-DC12V
	18	JW1SN-DC18V		18	JW2SN-DC18V
24	JW1SN-DC24V	24	JW2SN-DC24V		
48	JW1SN-DC48V	48	JW2SN-DC48V		

**High capacity (10 A) types**

Contact arrangement	Coil voltage, V DC	Part No.	Contact arrangement	Coil voltage, V DC	Part No.
1 Form A	5	JW1aFSN-DC5V	1 Form C	5	JW1FSN-DC5V
	6	JW1aFSN-DC6V		6	JW1FSN-DC6V
	9	JW1aFSN-DC9V		9	JW1FSN-DC9V
	12	JW1aFSN-DC12V		12	JW1FSN-DC12V
	18	JW1aFSN-DC18V		18	JW1FSN-DC18V
	24	JW1aFSN-DC24V		24	JW1FSN-DC24V
48	JW1aFSN-DC48V	48	JW1FSN-DC48V		

**COIL DATA (at 20°C 68°F)**

Nominal voltage, V DC	Pick-up voltage, V DC (max.) (Initial)	Drop-out voltage, V DC (min.) (Initial)	Nominal operating current, mA (±10%)	Coil resistance, Ω (±10%)	Nominal operating power, mW	Max. allowable voltage
5	3.5	0.5	106	47	530	130% V of Nominal Voltage (at 60°C 140°F)  120% V of Nominal Voltage (at 85°C 185°F)
6	4.2	0.6	88	68		
9	6.3	0.9	58	155		
12	8.4	1.2	44	270		
18	12.6	1.8	29	611		
24	16.8	2.4	22	1,100		
48	33.6	4.8	11	4,400		

# DIMENSIONS

## 1 Form A

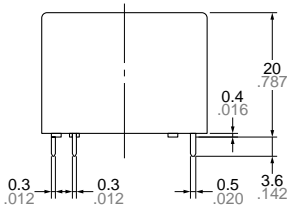

PC board pattern (Copper-side view)

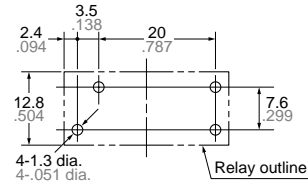

Tolerance:  $\pm 0.1 \pm .004$

Wiring diagram (Bottom view)

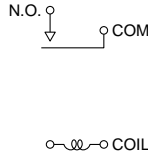

Dimension :	General tolerance
Max. 1mm .039 inch	$\pm 0.1 \pm .004$
1 to 3mm .039 to .118 inch	$\pm 0.2 \pm .008$
Min. 3mm .118 inch	$\pm 0.3 \pm .012$

## 1 Form C

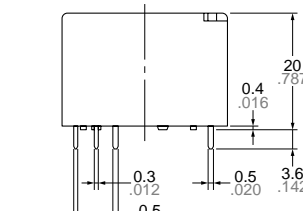

PC board pattern (Copper-side view)

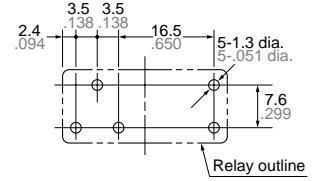

Tolerance:  $\pm 0.1 \pm .004$

Wiring diagram (Bottom view)

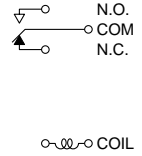

## 2 Form A

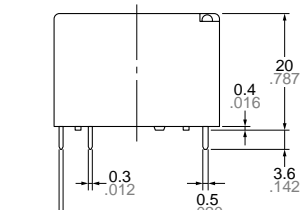

PC board pattern (Copper-side view)

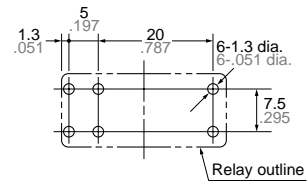

Tolerance:  $\pm 0.1 \pm .004$

Wiring diagram (Bottom view)

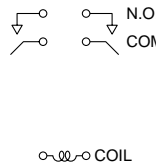

Dimension :	General tolerance
Max. 1mm .039 inch	$\pm 0.1 \pm .004$
1 to 3mm .039 to .118 inch	$\pm 0.2 \pm .008$
Min. 3mm .118 inch	$\pm 0.3 \pm .012$

## 2 Form C

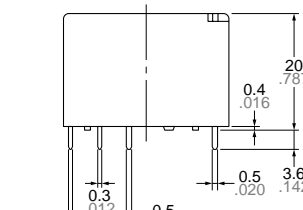

PC board pattern (Copper-side view)

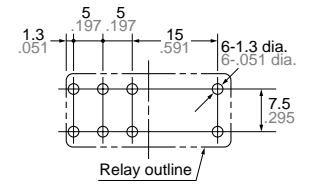

Tolerance:  $\pm 0.1 \pm .004$

Wiring diagram (Bottom view)

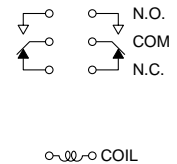

# REFERENCE DATA

1-(1). Maximum operating power  
1 Form A Standard (5 A) type

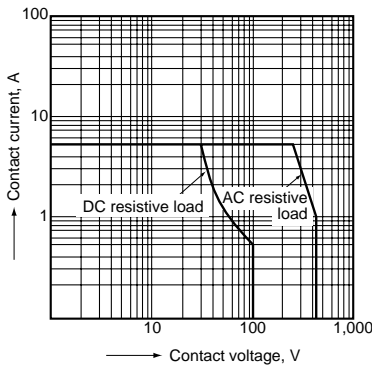

1-(2). Maximum operating power  
1 Form A High Capacity (10 A) type

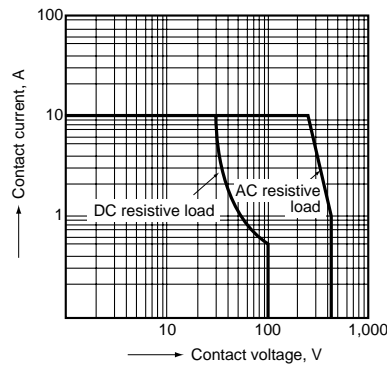

2-(1). Life curve  
1 Form A Standard (5 A) type

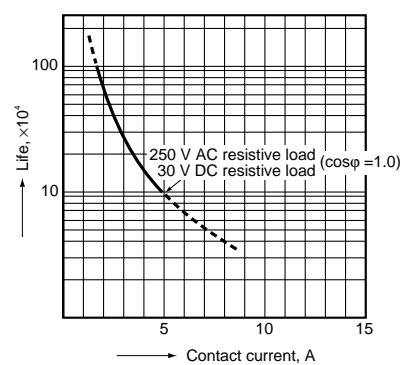

2-(2). Life curve

1 Form A High Capacity (10 A) type

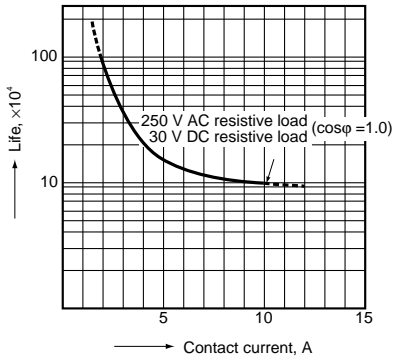

3-(1). Operate/release time

Sample: JW1aSN-DC12V, 10 pcs.  
Ambient temperature: 20°C 68°F

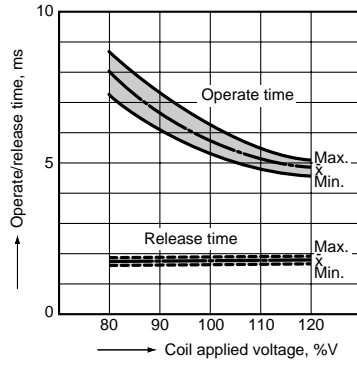

3-(2). Operate/release time

Sample: JW1aFSN-DC12V, 10 pcs.  
Ambient temperature: 20°C 68°F

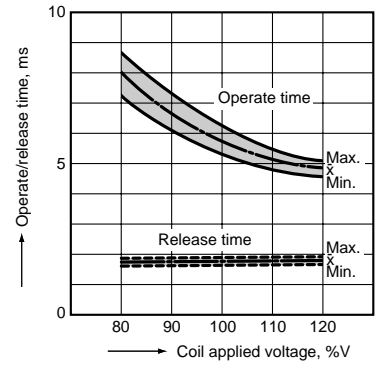

3-(3). Operate/release time

Sample: JW1SN-DC12V, 6 pcs.  
Ambient temperature: 20°C 68°F

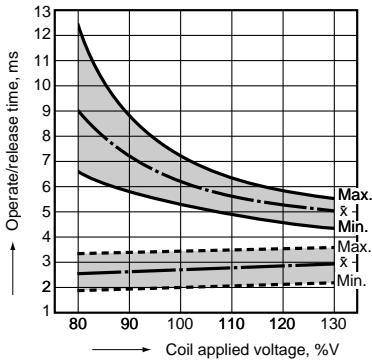

3-(4). Operate/release time

Sample: JW2aSN-DC24V, 6 pcs.  
Ambient temperature: 20°C 68°F

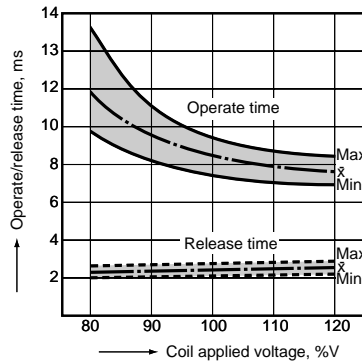

3-(5). Operate/release time

Sample: JW2SN-DC12V, 6 pcs.  
Ambient temperature: 20°C 68°F

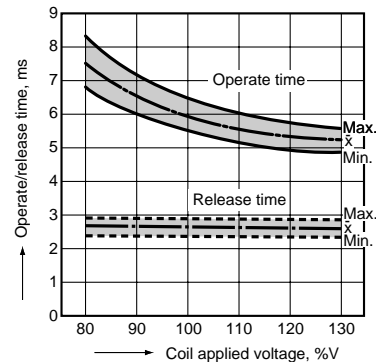

4-(1). Coil temperature rise

(Contact carrying current: 5A)  
Sample: JW1aFSN-DC12V, 6 pcs.  
Point measured: Inside the coil

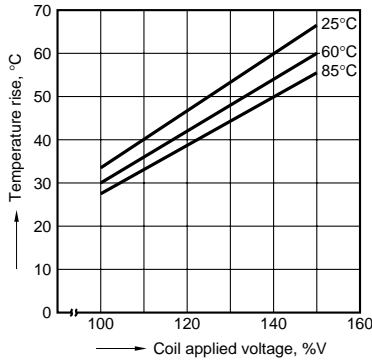

4-(2). Coil temperature rise

(Contact carrying current: 10 A)  
Sample: JW1aFSN-DC12V, 6 pcs.  
Point measured: Inside the coil

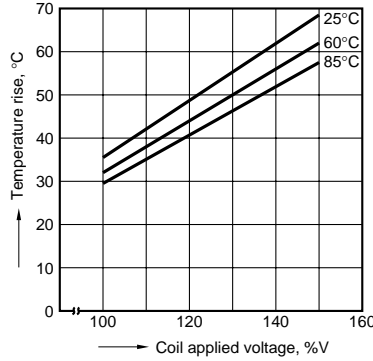

# ACCESSORIES

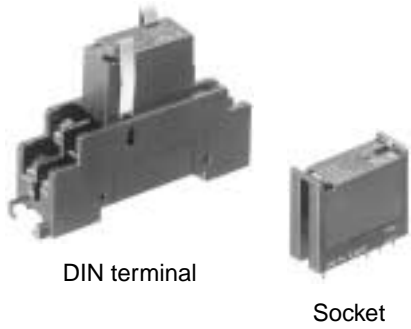

## FEATURES

1. Space saving design
2. Wiring can be done with ease (DIN terminal)

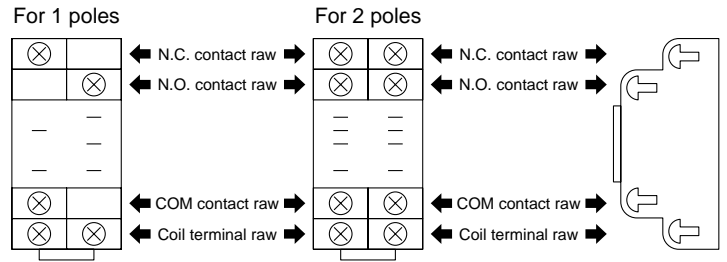

## TYPES

Product name	Number of poles	Part No.	Applicable relay type				Standard packing	
			1 Form A	1 Form C	2 Form A	2 Form C	Inner carton	Outer case
JW1 DIN terminal socket (with hold-down clip)	1	JW1-SFD	•	•			10 pcs.	100 pcs.
JW2 DIN terminal socket (with hold-down clip)	2	JW2-SFD			•	•		
JW1 PC board socket	1	JW1-PS	•	•				
JW2 PC board socket	2	JW2-PS			•	•		
JW1 Plug-in socket	1	JW1-SS	•	•				
JW2 Plug-in socket	2	JW2-SS			•	•		

## SPECIFICATIONS

Item	Type	PC board socket/Plug-in socket		DIN terminal socket	
		1 pole	2 poles	1 pole	2 poles
Breakdown voltage		1,500 vrms for 1 minute		1,500 Vrms for 1 minute	1,000 Vrms for 1 minute
Insulation resistance		Min. 100 MΩ		Min. 100 MΩ	

## DIMENSIONS

### 1. DIN terminal socket

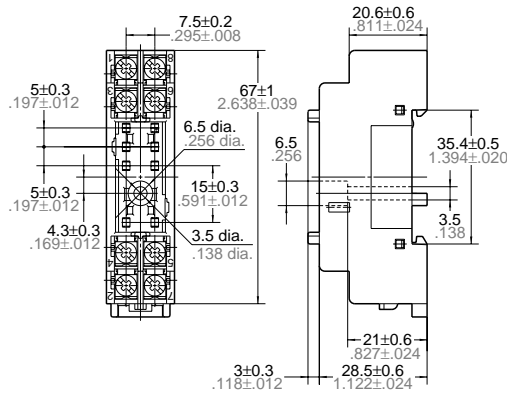

### 2. PC board socket

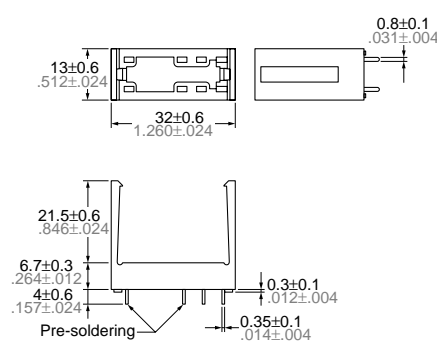

### PC board pattern (Bottom view)

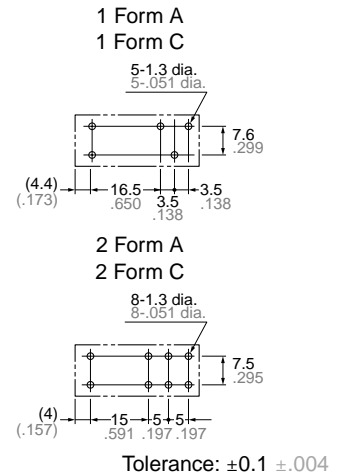

### 3. Plug-in socket

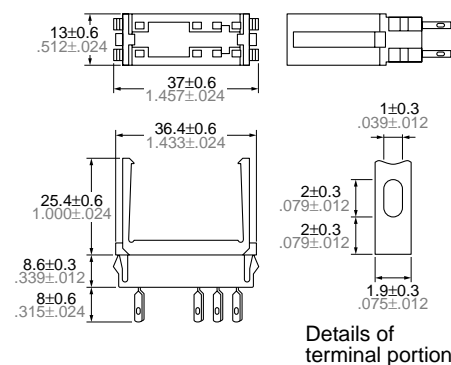

### Panel cut-out (Thickness: 1.0 to 2.0 .039 to .079)

