

# NAIS

## ULTRA-MINIATURE PC BOARD TYPE POWER RELAY

# JS RELAYS

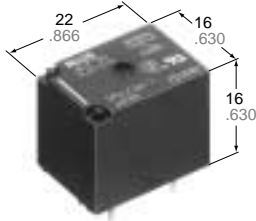

mm inch

### FEATURES

- Ultra-miniature size with universal terminal footprint
- High contact capacity: 10 A
- Class B coil insulation type available
- TV-5 type available
  - 1 Form A type → TV-5
  - 1 Form C type → TV-5 (N.O. side only)
- VDE, TÜV also approved
- Sealed construction for automatic cleaning

### SPECIFICATIONS

#### Contact

|  |   |  |
|--|---|--|
| Arrangement  | 1 Form A, 1 Form C  |  |
| Initial contact resistance, max.<br>(By voltage drop 6 V DC 1 A) | 100 mΩ  |  |
| Contact material   | Silver alloy  |  |
| Rating<br>(resistive load)                                       | Nominal switching capacity  | 10 A 250 V AC<br>10 A 125 V AC<br>6 A 277 V AC |
|  | Max. switching power  | 2,500 VA                                       |
|  | Max. switching voltage  | 250 V AC, 100 V DC                             |
|  | Max. switching current  | 10 A (AC), 5 A (DC)                            |
| Expected life<br>(min.ope.)                                      | Mechanical (at 180 cpm)   | 10 <sup>7</sup>                                |
|  | Electrical at 10 A 125 V AC,<br>6 A 277 V AC resistive<br>(at 20 cpm) | 10 <sup>5</sup>                                |
|  | 10 A 250 V AC resistive<br>(at 20 cpm)                                | 5 × 10 <sup>4</sup><br>(No contact only)       |

#### Coil

|                         |        |
|-------------------------|--------|
| Nominal operating power | 360 mW |
|-------------------------|--------|

#### Remarks

- \* Specifications will vary with foreign standards certification ratings.
- \*<sup>1</sup> Detection current: 10mA
- \*<sup>2</sup> Excluding contact bounce time
- \*<sup>3</sup> Half-wave pulse of sine wave: 11ms; detection time: 10μs
- \*<sup>4</sup> Half-wave pulse of sine wave: 6ms
- \*<sup>5</sup> Detection time: 10μs
- \*<sup>6</sup> Refer to 5. Conditions for operation, transport and storage mentioned in AMBIENT ENVIRONMENT (Page 24).
- \*<sup>7</sup> When using relays in a high ambient temperature, consider the pick-up voltage rise due to the high temperature (a rise of approx. 0.4% V for each 1°C 33.8°F with 20°C 68°F as a reference) and use a coil impressed voltage that is within the maximum allowable voltage range.

#### Characteristics

|   |                             |   |
|---|-----------------------------|---|
| Max. operating speed  | 20 cpm                      |   |
| Initial insulation resistance   | Min. 100 MΩ (at 500 V DC)   |   |
| Initial breakdown voltage* <sup>1</sup>   | Between open contacts       | 750 Vrms for 1 min.   |
|   | Between contacts and coil   | 1,500 Vrms for 1 min.   |
| Operate time* <sup>2</sup><br>(at nominal voltage)  | Approx. 10 ms               |   |
| Release time(without diode)* <sup>2</sup> (at nominal voltage)  | Approx. 10 ms               |   |
| Temperature rise (at nominal voltage)   | Max. 35°C                   |   |
| Shock resistance  | Functional* <sup>3</sup>    | Min. 98 m/s <sup>2</sup> {10 G}   |
|   | Destructive* <sup>4</sup>   | Min. 980 m/s <sup>2</sup> {100 G}   |
| Vibration resistance  | Functional* <sup>5</sup>    | Approx. 98 m/s <sup>2</sup> {10 G},<br>10 to 55 Hz at double amplitude of 1.6 mm  |
|   | Destructive                 | Approx. 117.6 m/s <sup>2</sup> {12 G},<br>10 to 55 Hz at double amplitude of 2 mm |
| Conditions for operation, transport and storage* <sup>6</sup><br>(Not freezing and condensing at low temperature) | Ambient temp.* <sup>7</sup> | -40°C to +85°C<br>-40°F to +185°F   |
|   | Humidity                    | 5 to 85% R.H.   |
| Unit weight   | Approx. 12 g .423 oz        |   |

### TYPICAL APPLICATIONS

1. Home appliances  
Air conditioner, heater, etc.
2. Automotive  
Power-window, car antenna, door-lock, etc.
3. Office machines  
PPC, facsimile, etc.
4. Vending machines

# ORDERING INFORMATION

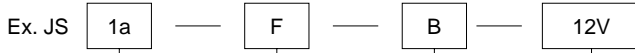

| Contact arrangement         | Protective construction                    | Coil insulation class                            | Coil voltage (DC)            |
|-----------------------------|--|--|------------------------------|
| 1: 1 Form C<br>1a: 1 Form A | Nil: Sealed type<br>F: Flux-resistant type | Nil: Class E insulation<br>B: Class B insulation | 5, 6, 9, 12, 18, 24,<br>48 V |

UL/CSA, VDE, TÜV approved type is standard.

Notes: 1. Standard packing: Carton: 100 pcs. Case: 500 pcs.

2. When ordering TV rated (TV-5) types, add suffix -TV.

# COIL DATA

| Part No.    |          |                     |          | Nominal voltage, V DC | Pick-up voltage, V DC (max.) (at 20°C/68°F) | Drop-out voltage, V DC (min.) (at 20°C/68°F) | Coil resistance, W (±10%) (at 20°C/68°F) | Nominal operating current, mA (±10%) (at 20°C/68°F) | Nominal operating power, mW (at 20°C/68°F) | Max. allowable voltage (at 85°C/185°F) |
|-------------|----------|---------------------|----------|-----------------------|---|--|--|---|--|--|
| Sealed type |          | Flux-resistant type |          |                       |   |  |  |   |  |  |
| 1 Form A    | 1 Form C | 1 Form A            | 1 Form C |                       |   |  |  |   |  |  |
| JS1a-5V     | JS1-5V   | JS1aF-5V            | JS1F-5V  | 5                     | 3.5   | 0.5  | 69.4                                     | 72  | 360  | 130%V of nominal voltage               |
| JS1a-6V     | JS1-6V   | JS1aF-6V            | JS1F-6V  | 6                     | 4.2   | 0.6  | 100                                      | 60  |  |  |
| JS1a-9V     | JS1-9V   | JS1aF-9V            | JS1F-9V  | 9                     | 6.3   | 0.9  | 225                                      | 40  |  |  |
| JS1a-12V    | JS1-12V  | JS1aF-12V           | JS1F-12V | 12                    | 8.4   | 1.2  | 400                                      | 30  |  |  |
| JS1a-18V    | JS1-18V  | JS1aF-18V           | JS1F-18V | 18                    | 12.6  | 1.8  | 900                                      | 20  |  |  |
| JS1a-24V    | JS1-24V  | JS1aF-24V           | JS1F-24V | 24                    | 16.8  | 2.4  | 1,600                                    | 15  |  |  |
| JS1a-48V    | JS1-48V  | JS1aF-48V           | JS1F-48V | 48                    | 33.6  | 4.8  | 6,400                                    | 7.5   |  |  |

# DIMENSIONS

mm inch

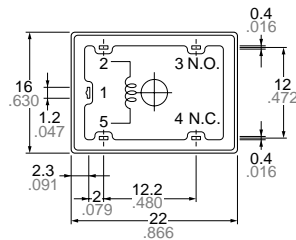
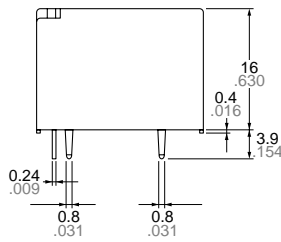

Note: Terminal No. 4 is only for 1 Form C type  
General tolerance: ±0.3 ±.012

## Schematic (Bottom view)

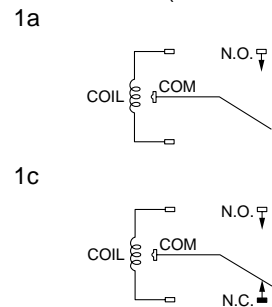

## PC board pattern (Copper-side view)

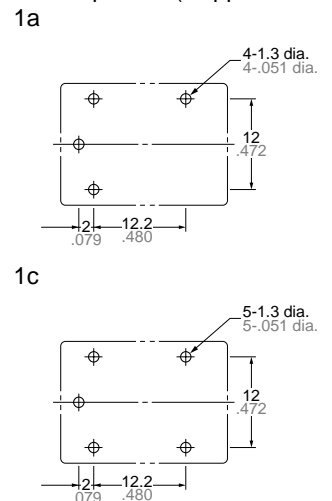

Tolerance: ±0.1 ±.004

REFERENCE DATA

1. Maximum value for switching capacity

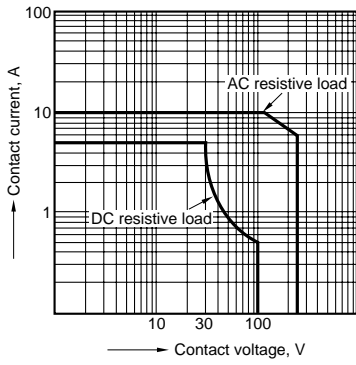

2. Operate/release time  
Sample: 25 pcs., JS1-12V

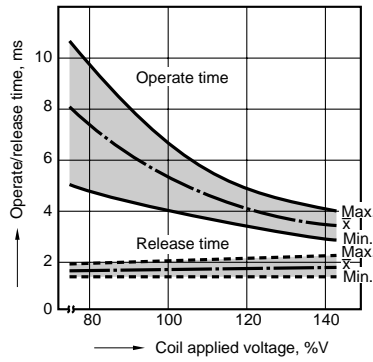

3. Life curve  
Ambient temperature: Room temperature

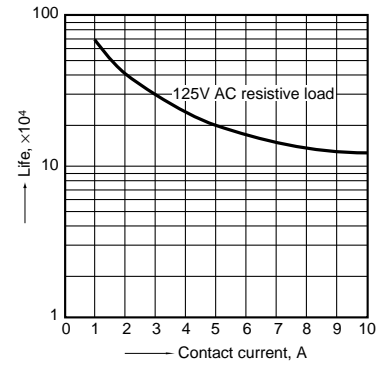

4-(1). Coil temperature rise  
Sample: 5 pcs., JS1a-24V  
Measured portion: Inside the coil  
Contact current: 5 A

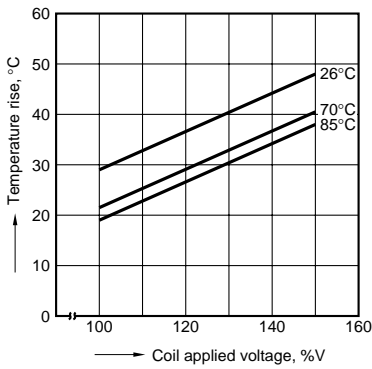

4-(2). Coil temperature rise  
Sample: 5 pcs., JS1a-24V  
Measured portion: Inside the coil  
Contact current: 10 A

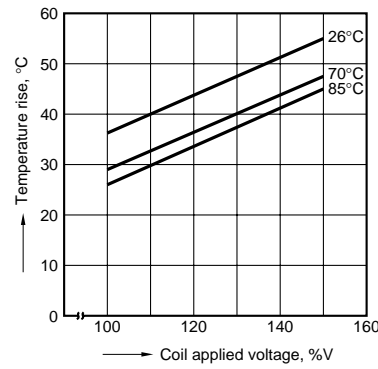

5. Ambient temperature characteristics  
Sample: 6 pcs., JS1-12V

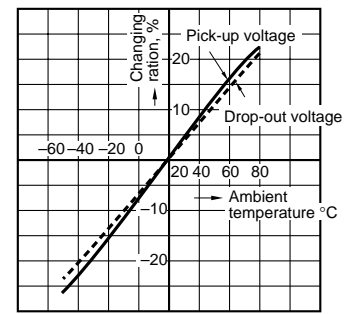

6. Electrical life test  
(10 A 125 V AC, resistive load)  
Sample: 6 pcs., JS1-12V  
Operating speed: 20 cpm  
Ambient temperature: room temperature

(Circuit)

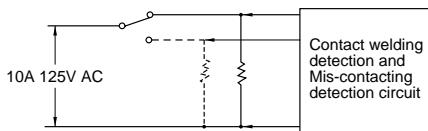

Change of pick-up and drop-out voltage

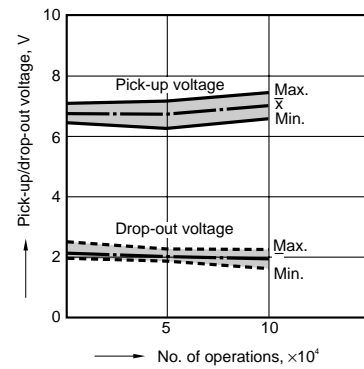

Change of contact resistance

